

Milling and Drilling Tools

for Composite and Honeycomb Materials





comprehensive training

Increased productivity equals lower cost, improved profitability, and ultimately, survival of your business in today's competitive environment. **The LMT Onsrud Performance Team** will work with all levels of your operation to increase your productivity. All levels of training, general to production-specific on the shop floor, are only a call away!

factory technical support

LMT Onsrud provides your business with access to our staff of highly trained professional factory technicians. We can assist you with those difficult production machining problems while increasing your performance and productivity.

on-site trouble shooting

Correct tool selection, proper hold-down techniques, faster feed rates, fewer and quicker set ups are all pieces to the productivity puzzle. **The LMT Onsrud Performance Team** offers tailored solutions for problem solving and productivity gains.

t h e
ONSRUD
a d v a n t a g e

custom tool design

Not only does LMT Onsrud offer the largest selection of cutting tools for day to day operations, but we will also design a tool for your specific application or material. We will take your tool requirements from the drawing board, to sophisticated computer-aided design, to in-house testing on our CNC router and CNC Mill. Custom tooling made to meet your productivity goals.

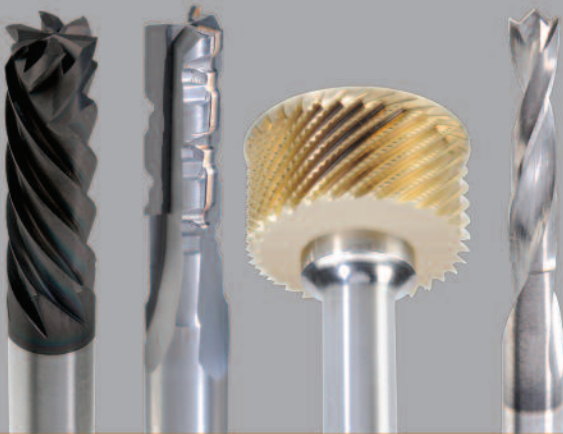

Composite

Composite

Honeycomb



























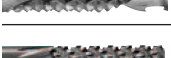

Drill

www.onsrud.com

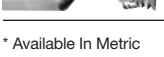
Table of Contents

Composites	4-11	Chiploads	24-25
Honeycomb	12-19	Quote Request Forms	26-37
Drills	20-23	Terms and Conditions	39

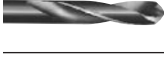
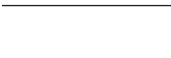
Table of Contents by Material

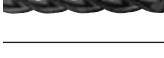
COMPOSITES		PAGE	HONEYCOMB		PAGE
	54-200* NEW SC 3F & 4F Spiral for Glass Reinforced Plastic	5		29-000 HSS Hollow Core Cutters	13
	56-000P SC 2F Straight	5		29-050 Diamond Grit Hogger	13
	63-000 SC 1F Upcut Spiral	6		29-100/29-100B* SC Honeycomb Hogger	14
	66-700* NEW DFC Multi-Flute Low Helix (Coated)	6		30-000 Replaceable Ring Type Honeycomb Cutter	14
	66-800* NEW DFC Compression for Composites	6		30-300 HSS Integral Shank Honeycomb Hogger Cutter	15
	66-900* NEW SC High Performance Composite Router	7		30-700 Reduced Weight Honeycomb Cutter	15
	67-000 SC Fiberglass Burr Bits	8		31-000 HSS Cutter	16
	67-200 SC 3F Phenolic/Composite Cutter	9		31-100 HSS Honeycomb Cutter with Teeth	16
	67-220 NEW PCD 3F Phenolic/Composite Cutter	9		32-000 HSS Hogger	17
	67-300 SC 2F Compression Spiral	9		32-200 NEW HSS 3 Piece Honeycomb Hogger	17
	67-400* SC Un-Ruffer	10		34-000 Aircraft Panel Tools	18
	67-500 SC Carbon Graphite Tool	10		34-100 NEW Potted Fastener Tools (Coated)	18
	68-000 2F PCD Tipped Tools	10	* Available In Metric		
	68-200* PCD 2F SERF Cutter	11	DRILLING		PAGE
	68-300* NEW PCD 3F SERF™ Cutter	11		67-800* SC 8 Facet Drill	21
	68-400* NEW PCD Ballnose	11		68-900 PCD 8 Facet Drills	22
				85-800* NEW SC CFRP Drills	23
				86-100 SC DFC Parabolic Drill	22

* Available In Metric

Table of Contents by Series Number

29-000	HSS Hollow Core Cutters	13	32-200	HSS 3 Piece Honeycomb Hogger	17	67-300	SC 2F Compression Spiral	9
29-050	Diamond Grit Hogger	13	34-000	Aircraft Panel Tools	18	67-400*	SC Un-Ruffer	10
29-100/ 29-100B	Solid Carbide Honeycomb Hogger	14	34-100	Potted Fastener Tools (Coated)	18	67-500	SC Carbon Graphite Tool	10
30-000	Replaceable Ring Type Honeycomb Cutter	14	54-200	SC 3F & 4F Spiral GRP (Coated)	5	67-800*	SC 8 Facet Drills	21
30-300	HSS Integral Shank Honeycomb Hogger Cutter	15	56-000P	SC 2F Straight	5	68-000	2F PCD Tipped Tools	10
30-700	Reduced Weight Honeycomb Cutter	15	63-000	SC 1F Upcut Spiral	6	68-200*	PCD 2F SERF	11
31-000	HSS Cutter	16	66-700	DFC Multi-Flute Low Helix (Coated)	6	68-300*	PCD 3F SERF	11
31-100	HSS Cutter with Teeth	16	66-800*	DFC Compression for Composites	6	68-400*	PCD Ballnose	11
32-000	HSS Hogger	17	66-900*	SC HiPerformance Composite Router	7	68-900	PCD 8 Facet Drills	22
			67-000	SC Fiberglass Burr Bits	8	85-800	SC CFRP Drills	23
			67-200	SC 3F Phenolic/Composite Cutter	9	86-100	SC DFC Parabolic Drills	22
			67-220	PCD Progressive Chipbreaker	9			

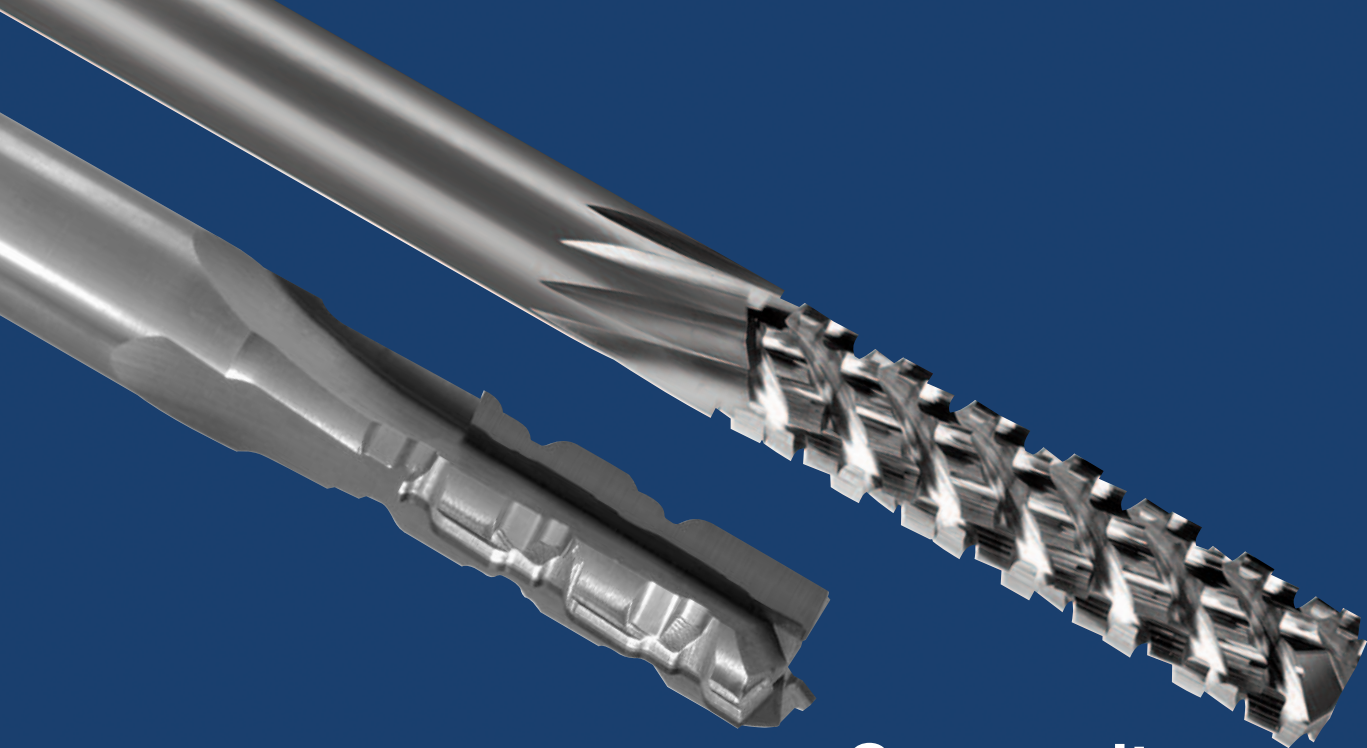

Composite Cutting Tools

Using metal cutting tools to machine today's highly abrasive composite materials can be costly in terms of tool wear and damage to workpieces. LMT Onsrud makes an extensive line of cutting tools designed for today's difficult-to-machine, space-age materials. LMT Onsrud manufactures solid carbide and PCD cutting tools designed specifically for machining CFRP (Carbon Fiber Reinforced Plastic), GRP (Glass Reinforced Plastic), Fiberglass, Phenolic, Kevlar®, Carbon Graphite and other composite materials.

Three & Four Flute - Solid Carbide Spiral for Glass-Reinforced Plastic (Coated)

Updated line of three and four flute tools for machining glass-reinforced plastic. Geometry has been optimized to shear the glass fibers while creating a chip which removes heat from the cut to avoid melting of the material. Tools are coated to withstand the abrasive characteristics inherent to glass-reinforced plastic (GRP).

Usage Fiberglass and Composites

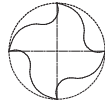

NEW

UPCUT

Part Number	Cutting DIA	Flute LGTH	SHK DIA	OAL	FLUTES
54-205	1/8	1/2	1/4	2-1/2	3
54-210	3/16	5/8	1/4	2-1/2	3
54-220	1/4	3/4	1/4	2-1/2	4
54-230	3/8	1-1/8	3/8	3	4
54-240	1/2	1-1/8	1/2	3-1/2	4

METRIC UPCUT

Part Number	Cutting DIA	Flute LGTH	SHK DIA	OAL	FLUTES
54-260	6mm	19mm	6mm	76mm	4
54-266	8mm	22mm	8mm	76mm	4
54-270	10mm	25mm	10mm	76mm	4
54-276	12mm	25mm	12mm	76mm	4

DOWNCUT

Part Number	Cutting DIA	Flute LGTH	SHK DIA	OAL	FLUTES
54-206	1/8	1/2	1/4	2-1/2	3
54-211	3/16	5/8	1/4	2-1/2	3
54-221	1/4	3/4	1/4	2-1/2	4
54-231	3/8	1-1/8	3/8	3	4
54-241	1/2	1-1/8	1/2	3-1/2	4

METRIC DOWNCUT

Part Number	Cutting DIA	Flute LGTH	SHK DIA	OAL	FLUTES
54-261	6mm	19mm	6mm	76mm	4
54-267	8mm	22mm	8mm	76mm	4
54-271	10mm	25mm	10mm	76mm	4
54-277	12mm	25mm	12mm	76mm	4

Double Flute - Solid Carbide Straight

Designed specifically to rout harder, more rigid plastics.

Usage Foam, fiberglass, phenolic, acrylic, nylon, PVC, ABS, acetal and solid surface

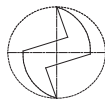

Part Number	Cutting DIA	Flute LGTH	SHK DIA	OAL
56-041	1/8	1/4	1/4	2
56-061	3/16	3/8	1/4	2
56-062	3/16	5/8	1/4	2
56-062L	3/16	5/8	1/4	2
56-063*	3/16	5/8	1/4	4
56-081	1/4	3/8	1/4	2-1/2
56-082	1/4	3/4	1/4	2-1/2
56-082L	1/4	3/4	1/4	2-1/2
56-086*	1/4	1-1/4	1/4	4
56-121	3/8	5/8	3/8	2-1/2
56-122	3/8	7/8	3/8	2-1/2
56-122L	3/8	7/8	3/8	2-1/2
56-124*	3/8	1-5/8	3/8	6
56-162	1/2	1	1/2	3
56-162L	1/2	1	1/2	3
56-164	1/2	2-1/8	1/2	6

* These tools are designed and toleranced for Air Routers with guide
L = Left Hand Rotation

63-000



Single Flute - Solid Carbide Upcut Spiral

Designed for routing where upward chip removal, tool rigidity, long life, and high quality finish is desired.

Usage Fiberglass, phenolic and aluminum

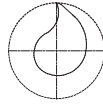

Part Number	Cutting DIA	Flute LGTH	SHK DIA	OAL
63-040	1/8	1/2	1/4	2
63-050	5/32	9/16	1/4	2
63-060	3/16	5/8	1/4	2
63-080	1/4	3/4	1/4	2-1/2
63-100	5/16	13/16	3/8	2-1/2
63-160	1/2	1	1/2	3

HELIX ANGLE ≈ 30°

66-700



DFC Multi-Flute Low Helix (Coated)

The diamond film coated (CVD) solid carbide multi-flute low helix tools are designed to produce superior edge quality and finish in composite materials at higher feed rates than a PCD tool.

Usage Composite

Part Number	Cutting DIA	Flute LGTH	SHK DIA	OAL	Flutes
66-705	1/4	3/4	1/4	3-1/2	6
66-710	3/8	1-1/8	3/8	4	8
66-715	1/2	1-1/2	1/2	4	10

METRIC

Part Number	Cutting DIA	Flute LGTH	SHK DIA	OAL	Flutes
66-725	8mm	25mm	8mm	100mm	8
66-730	10mm	30mm	10mm	100mm	8
66-735	12mm	40mm	12mm	100mm	10

NEW

66-800



DFC Compression for Composites (Coated)

The diamond film coated (CVD) solid carbide compression routers unique geometry prevents delamination on top and the bottom edges of the composites. The open flute geometry dissipates heat to prevent resin flow.

Usage Composite

Part Number	Cutting DIA	Flute LGTH	Upcut LGTH	SHK DIA	OAL	Flutes
66-802DFC	1/4	3/4	.325	1/4	3-1/2	4
66-811DFC*	3/8	1	.100	3/8	4	4
66-814DFC	3/8	1	.340	3/8	4	6
66-817DFC*	1/2	1-1/8	.100	1/2	4	6
66-823DFC	1/2	1-1/8	.350	1/2	4	6

*DOWNCUT EDGE TO WITHIN .050" OF TOOL END

METRIC

Part Number	Cutting DIA	Flute LGTH	Upcut LGTH	SHK DIA	OAL	Flutes
66-852DFC	6mm	20mm	7.75mm	6mm	90mm	4
66-858DFC	8mm	25mm	8mm	8mm	100mm	4
66-864DFC	10mm	25mm	8.5mm	10mm	100mm	6
66-870DFC	12mm	25mm	9mm	12mm	100mm	6

NEW

High Performance Composite Router (Coated)

The new High Performance Composite Router is designed for more efficient routing of composite materials, in both hand-fed and in CNC applications. Coated for increased tool life.

Usage Composites and fiberglass

Part Number	Point Style	Cutting DIA	Flute LGTH	SHK DIA	OAL
66-901ALTIN	No	1/8	1/2	1/8	1-1/2
66-902ALTIN	BURR	1/8	1/2	1/8	1-1/2
66-903ALTIN	Endmill	1/8	1/2	1/8	1-1/2
66-904ALTIN	Drill	1/8	1/2	1/8	1-1/2
66-905ALTIN	No	3/16	5/8	1/4	2
66-906ALTIN	BURR	3/16	5/8	1/4	2
66-907ALTIN	Endmill	3/16	5/8	1/4	2
66-908ALTIN	Drill	3/16	5/8	1/4	2
66-909ALTIN	No	1/4	1	1/4	3
66-910ALTIN	BURR	1/4	1	1/4	3
66-911ALTIN	Endmill	1/4	1	1/4	3
66-912ALTIN	Drill	1/4	1	1/4	3
66-913ALTIN	No	1/4	1-1/2	1/4	3-1/2
66-914ALTIN	BURR	1/4	1-1/2	1/4	3-1/2
66-915ALTIN	Endmill	1/4	1-1/2	1/4	3-1/2
66-916ALTIN	Drill	1/4	1-1/2	1/4	3-1/2
66-917ALTIN	No	1/4	2-1/8	1/4	4
66-918ALTIN	BURR	1/4	2-1/8	1/4	4
66-919ALTIN	Endmill	1/4	2-1/8	1/4	4
66-920ALTIN	Drill	1/4	2-1/8	1/4	4
66-921ALTIN	No	3/8	1	3/8	3
66-922ALTIN	BURR	3/8	1	3/8	3
66-923ALTIN	Endmill	3/8	1	3/8	3
66-924ALTIN	Drill	3/8	1	3/8	3
66-925ALTIN	No	3/8	1-5/8	3/8	3-1/2
66-926ALTIN	BURR	3/8	1-5/8	3/8	3-1/2
66-927ALTIN	Endmill	3/8	1-5/8	3/8	3-1/2
66-928ALTIN	Drill	3/8	1-5/8	3/8	3-1/2
66-929ALTIN	No	3/8	2-1/8	3/8	4
66-930ALTIN	BURR	3/8	2-1/8	3/8	4
66-931ALTIN	Endmill	3/8	2-1/8	3/8	4
66-932ALTIN	Drill	3/8	2-1/8	3/8	4
66-933ALTIN	No	1/2	1-1/8	1/2	3
66-934ALTIN	BURR	1/2	1-1/8	1/2	3
66-935ALTIN	Endmill	1/2	1-1/8	1/2	3
66-936ALTIN	Drill	1/2	1-1/8	1/2	3
66-937ALTIN	No	1/2	1-5/8	1/2	4
66-938ALTIN	BURR	1/2	1-5/8	1/2	4

Part Number	Point Style	Cutting DIA	Flute LGTH	SHK DIA	OAL
66-939ALTIN	Endmill	1/2	1-5/8	1/2	4
66-940ALTIN	Drill	1/2	1-5/8	1/2	4
66-941ALTIN	No	1/2	2-1/8	1/2	4
66-942ALTIN	BURR	1/2	2-1/8	1/2	4
66-943ALTIN	Endmill	1/2	2-1/8	1/2	4
66-944ALTIN	Drill	1/2	2-1/8	1/2	4
66-945ALTIN	No	1/2	3-1/8	1/2	5
66-946ALTIN	BURR	1/2	3-1/8	1/2	5
66-947ALTIN	Endmill	1/2	3-1/8	1/2	5
66-948ALTIN	Drill	1/2	3-1/8	1/2	5
66-949ALTIN	No	1/2	4-1/8	1/2	6
66-950ALTIN	BURR	1/2	4-1/8	1/2	6
66-951ALTIN	Endmill	1/2	4-1/8	1/2	6
66-952ALTIN	Drill	1/2	4-1/8	1/2	6
66-971ALTIN	No	4mm	16mm	6mm	50mm
66-972ALTIN	BURR	4mm	16mm	6mm	50mm
66-973ALTIN	Endmill	4mm	16mm	6mm	50mm
66-974ALTIN	Drill	4mm	16mm	6mm	50mm
66-975ALTIN	No	6mm	19mm	6mm	75mm
66-976ALTIN	BURR	6mm	19mm	6mm	75mm
66-977ALTIN	Endmill	6mm	19mm	6mm	75mm
66-978ALTIN	Drill	6mm	19mm	6mm	75mm
66-979ALTIN	No	6mm	25mm	6mm	75mm
66-980ALTIN	BURR	6mm	25mm	6mm	75mm
66-981ALTIN	Endmill	6mm	25mm	6mm	75mm
66-982ALTIN	Drill	6mm	25mm	6mm	75mm
66-983ALTIN	No	8mm	25mm	8mm	63mm
66-984ALTIN	BURR	8mm	25mm	8mm	63mm
66-985ALTIN	Endmill	8mm	25mm	8mm	63mm
66-986ALTIN	Drill	8mm	25mm	8mm	63mm
66-987ALTIN	No	10mm	25mm	10mm	75mm
66-988ALTIN	BURR	10mm	25mm	10mm	75mm
66-989ALTIN	Endmill	10mm	25mm	10mm	75mm
66-990ALTIN	Drill	10mm	25mm	10mm	75mm
66-991ALTIN	No	12mm	25mm	12mm	75mm
66-992ALTIN	BURR	12mm	25mm	12mm	75mm
66-993ALTIN	Endmill	12mm	25mm	12mm	75mm
66-994ALTIN	Drill	12mm	25mm	12mm	75mm



NEW



Burr Point

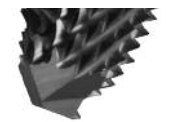

Drill Point



End Mill Point



No Point

67-000
67-250

Solid Carbide Fiberglass Router

Designed as fiberglass routers. Their upcut/downcut diamond design effectively shears fibrous materials.

Usage Fiberglass and Composite



MEDIUM BURR W/END MILL POINT

Part Number	Cutting DIA	Flute LGTH	SHK DIA	OAL
67-003	1/8	1	1/8	2
67-010	1/4	3/4	1/4	2-1/2
67-011	1/4	1-1/8	1/4	3
67-012	1/4	1-1/4	1/4	3
67-014	1/4	1-1/2	1/4	3
67-017	1/4	2-1/8	1/4	4
67-030	3/8	7/8	3/8	2-1/2

MEDIUM BURR W/END MILL POINT

Part Number	Cutting DIA	Flute LGTH	SHK DIA	OAL
67-023	3/8	1-5/8	3/8	3
67-027	3/8	2-1/8	3/8	4
67-031	1/2	1-1/8	1/2	3
67-033	1/2	1-5/8	1/2	4
67-037	1/2	2-1/8	1/2	4
67-039	1/2	3-1/8	1/2	5
67-065	3/4	4-1/8	3/4	6



MEDIUM BURR W/DRILL POINT

Part Number	Cutting DIA	Flute LGTH	SHK DIA	OAL
67-080	1/4	3/4	1/4	2-1/2
67-120	3/8	7/8	3/8	2-1/2
67-160	1/2	1	1/2	3



3 FLUTE DOWNCUT DIAMOND GRIT TOOL

Part Number	Cutting DIA	Flute LGTH	SHK DIA	OAL
67-254	1/4	1-1/8	1/4	3

3 FLUTE DOWNCUT DIAMOND GRIT TOOL

Part Number	Cutting DIA	Flute LGTH	SHK DIA	OAL
67-256	1/4	1-3/8	1/4	3
67-258	3/8	1-3/8	3/8	3

Three Flute - Solid Carbide Phenolic Cutter

67-200

Equally adaptable to low or high spindle speed applications in any CNC machining environment. The free cutting action of the tools provides for better finishes and significantly lower noise levels.

Usage Phenolic

UPCUT

Part Number	Cutting DIA	Flute LGTH	SHK DIA	OAL
67-205	3/8	7/8	3/8	3
67-211	1/2	1-1/8	1/2	3
67-215	1/2	2-1/8	1/2	4

HELIX ANGLE ≈ 10°

METRIC UPCUT

Part Number	Cutting DIA	Flute LGTH	SHK DIA	OAL
67-207	10mm	22mm	10mm	75mm
67-209	12mm	28mm	12mm	75mm

HELIX ANGLE ≈ 10°

DOWNCUT

Part Number	Cutting DIA	Flute LGTH	SHK DIA	OAL
67-206	3/8	7/8	3/8	3
67-212	1/2	1-1/8	1/2	3-1/2
67-216	1/2	2-1/8	1/2	4-1/2



Three Flute - PCD Progressive Chipbreaker for Composites

67-220

Provides superior chip control and increased tool life when cutting dense and abrasive materials. The new chipbreaker incorporates a unique geometry with a PCD cutting edge to support a wide range of feed rates and depth of cut combinations while extending the life of the tool. This is accomplished by utilizing a distinct Hi-Low asymmetrical chipbreaker profile which reduces vibration and chatter, caused by harmonic imbalance, resulting in improved surface finishes, while reducing noise levels and wear on the tool.

Usage Composites and phenolic

Part Number	Cutting DIA	Flute LGTH	SHK DIA	OAL
67-221	3/8	3/8	3/8	3
67-225	1/2	5/8	1/2	3
67-227	1/2	1-1/8	1/2	3

METRIC

Part Number	Cutting DIA	Flute LGTH	SHK DIA	OAL
67-230	10mm	12mm	10mm	76mm
67-233	12mm	20mm	12mm	100mm



NEW

Double Flute - Solid Carbide Compression Spiral

67-300

Compression design for fast feed and excellent finish on both sides of the material.

Usage Composite panels and honeycomb core

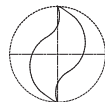

Part Number	Cutting DIA	Flute LGTH	SHK DIA	OAL	Diamond Coated Part Number
67-305	1/4	7/8	1/4	2-1/2	-
67-314	3/8	1-1/8	3/8	3	67-314DFC
67-320*	1/2	7/8	1/2	3	-
67-322	1/2	1-1/8	1/2	3	67-322DFC

* = Mortise Compression

HELIX ANGLE ≈ 30°



67-400



Solid Carbide Un-Ruffer™^{PATENTED}

The unique design allows for the cutting performance of a burr while achieving a good surface finish.

Usage Composite panels

METRIC

Part Number	Cutting DIA	Flute LGTH	SHK DIA	OAL
67-426M	6mm	25mm	6mm	64mm
67-435M	10mm	25mm	10mm	76mm
67-445M	12mm	25mm	12mm	76mm

Part Number	Cutting DIA	Flute LGTH	SHK DIA	OAL
67-423	1/4	3/4	1/4	2
67-426	1/4	1	1/4	2-1/2
67-428	1/4	1	1/4	3
67-435	3/8	1	3/8	3
67-445	1/2	1	1/2	3

67-500



Solid Carbide CG Tool (Carbon Graphite)

The geometry of these tools increases the amount of effective cutting flutes resulting in superior performance over a standard burr.

Usage Carbon graphite and carbon fiber panels

Part Number	Cutting DIA	Flute LGTH	SHK DIA	OAL
67-505	1/8	1/2	1/8	2
67-508	3/16	5/8	3/16	2
67-511	1/4	3/4	1/4	3
67-514	1/4	1-1/2	1/4	3
67-520	3/8	1-1/8	3/8	3-1/2
67-523	1/2	1-1/8	1/2	3-1/2
67-526	1/2	2-1/8	1/2	4

68-000



Double Flute - PCD Tipped Tooling

Designed for use in abrasive materials where cut quality and tool life are important.

Usage Composite panels and fiberglass



PCD Full Face



PCD Full Face with Plunge Point

PCD FULL FACE

Part Number	Cutting DIA	Flute LGTH	SHK DIA	OAL
68-005	1/4	3/4	1/4	3
68-010	3/8	3/4	3/8	3
68-020	1/2	3/4	1/2	4
68-030	3/4	1	3/4	4

HELIX ANGLE ≈ 0-3°

PCD FULL FACE with PLUNGE POINT

Part Number	Cutting DIA	Flute LGTH	SHK DIA	OAL
68-050	1/4	3/4	1/4	3
68-055	3/8	7/8	3/8	3
68-062	1/2	1-1/4	1/2	4
68-070	3/4	1-1/4	3/4	4
68-072	3/4	1-1/4	3/4	4

Down Shear

Double Flute - PCD SERF™ Cutter

This tool is designed to act like a rougher and finishing tool in one. The unique geometry reduces the cutting forces resulting in longer tool life, higher feed rates and reduced noise.

Usage Composites

METRIC

Part Number	Cutting DIA	Flute LGTH	SHK DIA	OAL
68-213M	6mm	20mm	6mm	76mm
68-226M	10mm	25mm	10mm	88mm
68-236M	12mm	32mm	12mm	100mm

Part Number	Cutting DIA	Flute LGTH	SHK DIA	OAL
68-210	1/4	3/8	1/4	3
68-213	1/4	3/4	1/4	3
68-216	1/4	1	1/4	3-1/2
68-220	3/8	3/8	3/8	3
68-223	3/8	3/4	3/8	3
68-226	3/8	1	3/8	3-1/2
68-230	1/2	3/4	1/2	4
68-233	1/2	1	1/2	4
68-236	1/2	1-1/4	1/2	4

68-200



Three Flute - PCD SERFIN™ Cutter

Three-Flute tool with two roughing edges that have geometry to reduce cutting forces and shear fibers in high-strength composite and other fiber reinforced plastic materials. The finishing edge cleans up after roughing cuts to create a smooth edge on material.

Usage Composites

Part Number	Cutting DIA	Flute LGTH	SHK DIA	OAL
68-315	3/8	1/2	3/8	4
68-320	3/8	7/8	3/8	4
68-340	1/2	5/8	1/2	4
68-345	1/2	1	1/2	4
68-350	1/2	1-1/4	1/2	4
68-360	3/4	1-3/8	3/4	5

METRIC

Part Number	Cutting DIA	Flute LGTH	SHK DIA	OAL
68-310	8mm	10mm	8mm	76mm
68-325	10mm	14mm	10mm	100mm
68-330	12mm	14mm	12mm	100mm
68-335	12mm	26mm	12mm	100mm
68-355	16mm	26mm	16mm	100mm

68-300



NEW

Double Flute - PCD Ballnose

Designed for use in abrasive materials where cut quality and tool life are important.

Usage Composites

Part Number	Cutting DIA	Flute LGTH	SHK DIA	OAL
68-405	1/4	3/8	1/4	2-1/2
68-410	3/8	1/2	3/8	3
68-420	1/2	5/8	1/2	4
68-425	5/8	7/8	5/8	4
68-430	3/4	1	3/4	4

METRIC

Part Number	Cutting DIA	Flute LGTH	SHK DIA	OAL
68-440	6mm	10mm	6mm	76mm
68-445	8mm	10mm	8mm	76mm
68-450	10mm	12mm	10mm	76mm
68-455	12mm	20mm	12mm	100mm

68-400



NEW



Honeycomb Cutters & Hogs

LMT Onsrud produces the industry's largest selection of cutting tools used to machine honeycomb core and sandwiched structured composite panels. These materials are used where ever strong, yet, lightweight construction is needed in aerospace, marine, transportation and wind energy applications. LMT Onsrud manufactures roughing tools, used for rapid stock removal, finishing tools for detail work such as contouring, carving and chamfering and specialty panel tools for cutting, sizing and grooving panel material.

HSS Hollow Core Cutters

This specialized cutter is designed to vertically cut the honeycomb cells producing a clean, flag free edge. The core material will remain attached at the bottom and can be removed using one of our valve style honeycomb cutters. This product along with our 31-100 or 30-000 series tools is an effective combination to create pockets in honeycomb core and get a perfectly clean edge.

Usage Honeycomb

Part Number	Cutting DIA	Flute LGTH	SHK DIA	OAL
29-003	1/4	1-1/2	1/4	3-3/4
29-006	3/8	1-7/8	3/8	3-3/4
29-009	1/2	2-7/8	1/2	5
29-012	5/8	2-7/8	5/8	5
29-015	3/4	2-7/8	3/4	5

29-000



Diamond Grit Hogger

Diamond grit hoggers are used on abrasive cores (graphite, phenolic, or fiberglass) in order to achieve long tool life. The tools are available in a ball nose version and as a traditional hogger capable of holding existing honeycomb blades. A 35% weight reduction has been designed into the larger diameter tools resulting in better performance on 3 or 5 axis machines.

Usage Honeycomb

BALL NOSE

Part Number	Cutting DIA	Flute LGTH	SHK DIA	OAL
29-053	1/4 (6.35mm)	1 1/4	1/4	4
29-058	3/8 (9.52mm)	2 1/2	1/2	4
29-063	1/2 (12.7mm)	3	1/2	5
29-068	3/4 (19.05mm)	3	1/2	5
29-074	1 (25.4mm)	2	3/4	4

29-050



HONEYCOMB HOGGER					CUTTING BLADE OPTIONS							SPARE PARTS	
Part #	Cutting Diameter	Hogger Depth	Shank DIA	OAL	Blade Diameter	HSS	HSS w/Teeth	Solid Carbide	Solid Carbide w/Teeth	Diamond Plated	HSS Saw	Adapter Ring	Screw
29-052	1/4 (6.35mm)	1 1/4	1/4	4	-	-	-	-	-	-	-	-	-
29-057	.345 (8.76mm)	2 1/2	1/2	4	3/8 (9.52mm)	30-016	30-316	-	-	-	-	-	HRD51646
29-062	.470 (11.94mm)	3	1/2	5	1/2 (12.7mm)	30-017	30-317	-	-	-	-	-	HRD51646
29-067	.720 (18.28mm)	3	1/2	5	3/4 (19.05mm)	-	-	30-015	30-318	-	-	-	30-011-2
29-072	.970 (24.63mm)	1	1/2	3	1 (25.4mm)	-	-	30-012	30-313	30-113	30-213	-	30-011-2
29-073'	.970 (24.63mm)	2	3/4	5	1 (25.4mm)	-	-	30-012	30-313	30-113	30-213	-	30-011-2
29-078	1.470 (37.33mm)	1	1/2	3	1 1/2 (38.10mm)	-	-	30-014	30-314	30-114	30-214	30-020-3	30-020-4
29-079'	1.470 (37.33mm)	2	3/4	5	1 1/2 (38.10mm)	-	-	30-014	30-314	30-114	30-214	30-020-3	30-020-4
29-083	1.742 (44.24mm)	1	1/2	3	1.772 (45mm)	-	-	30-026	30-326	30-126°	30-226°	30-020-3	30-020-4
29-084'	1.742 (44.24mm)	2	3/4	5	1.772 (45mm)	-	-	30-026	30-326	30-126°	30-226°	30-020-3	30-020-4
29-088	1.970 (50.03mm)	1	5/8	3	2 (50.8mm)	-	-	30-022	30-322	30-122	30-222	30-020-3	30-020-4
29-089'	1.970 (50.03mm)	2	3/4	5	2 (50.8mm)	-	-	30-022	30-322	30-122	30-222	30-020-3	30-020-4
29-093	2.450 (62.23mm)	1	5/8	3	2.480 (63mm)	-	-	30-036	30-336	30-136	30-236	30-030-3	30-030-4
29-095	2.970 (75.43mm)	1	3/4	3	3 (76.20mm)	-	-	30-032	30-332	30-132	30-232	30-030-3	30-030-4
29-096'	2.970 (75.43mm)	1	3/4	4	3 (76.20mm)	-	-	30-032	30-332	30-132	30-232	30-030-3	30-030-4
29-098	3.970 (100.83mm)	1	3/4	3	4 (101.6mm)	-	-	30-042	30-342	30-142	30-242	30-040-3	30-040-4
29-099'	3.970 (100.83mm)	1	3/4	4	4 (101.6mm)	-	-	30-042	30-342	30-142	30-242	30-040-3	30-040-4

1 = non-stock standard. 4 week lead time
2 = 50mm diameter honecomb blade

See page 14 or 16 for Images of Cutting Blades

29-100/ 29-100B

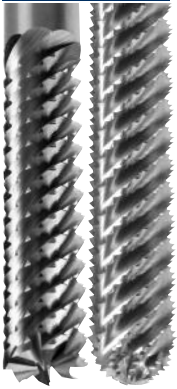

Solid Carbide Honeycomb Hogger (Coated)

Designed to be a versatile tool and cut most honeycomb core materials. The solid carbide body offers long tool life while the proven hogger geometry shreds the core and evacuates chips. The long flute length allows for deep pocket applications and can also be used to surface large areas. Hoggers are coated with ZRN.

Usage Honeycomb

METRIC

Part Number	Cutting DIA	Flute LGTH	SHK DIA	OAL
29-120	12 (.472")	60	12	150
29-135	16 (.629")	80	16	150

Part Number	Cutting DIA	Flute LGTH	SHK DIA	OAL
29-110	1/4 (6.35mm)	1-1/4	1/4	4
29-115	3/8 (9.52mm)	2	3/8	4
29-125	1/2 (12.7mm)	3	1/2	6
29-130	1/2 (12.7mm)	4-1/2	1/2	6-1/2
29-140	3/4 (19.05mm)	3	3/4	6
29-145	3/4 (19.05mm)	4-1/2	3/4	6-1/2

BALLNOSE

Part Number	Cutting DIA	Flute LGTH	SHK DIA	OAL
29-130B	1/2 (12.7mm)	4-1/2	1/2	6-1/2
29-140B	3/4 (19.05mm)	3	3/4	6
29-145B	3/4 (19.05mm)	4-1/2	3/4	6-1/2

30-000



Replaceable Ring Type Honeycomb Cutter

These tools are for contouring, carving and chamfering cuts of .25" or less. The unique patented holding system prevents the solid carbide blades from coming out of the holder if it is fractured.

Usage For contouring, carving and chamfering cuts

The HSS saw blades and the diamond plated blades dish on the bottom so they clear the cut core finish like the hollow ground solid carbide style rings. The solid carbide rings may be reground several times at the factory making them very economical to use.

The HSS saw and diamond plated blades are disposable, offering the convenience of a constant diameter.

SHANK ASSEMBLY			CUTTING BLADE OPTIONS				SPARE PARTS	
Part #	Blade Diameter	Shank DIA	Solid Carbide	Solid Carbide with Teeth	Diamond Plated	HSS Saw	Adapter Ring	Screw
30-011	1" (25.4mm)	1/2	30-012	30-313	30-112	30-213	-	30-011-2
30-021	2" (50.8mm)	1/2	30-022	30-322	30-122	30-222	30-020-3	30-020-4
30-031	3" (76.2mm)	1/2	30-032	30-332	30-132	30-232	30-030-3	30-030-4
30-041	4" (101.6mm)	1/2	30-042	30-342	30-142	30-242	30-040-3	30-040-4

See page 14 or 16 for Images of Cutting Blades

Cutting Blades for Cutters and Hoggers

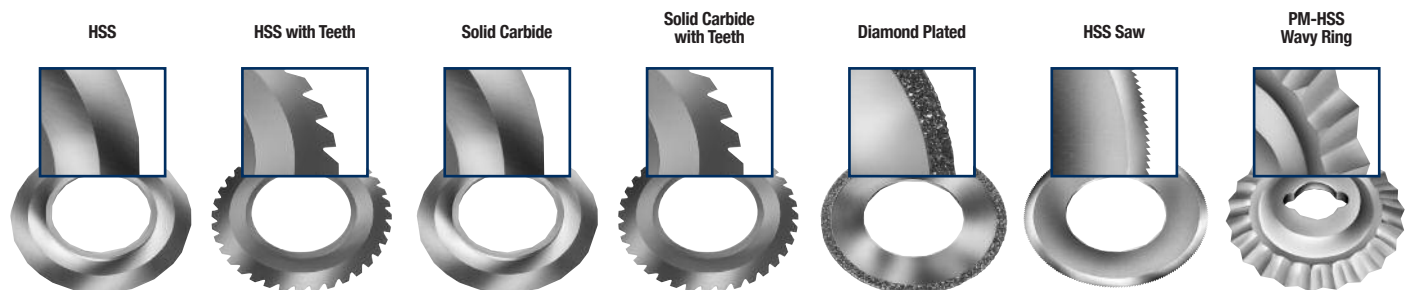

HSS Integral Shank Honeycomb Hogger Cutter

**High Speed Steel Hoggers • High Speed Replaceable Saw Blade
Solid Carbide Replaceable Blade • Diamond Plated Replaceable Blade**

The spiral hogger geometry ground integral to the shank allows for faster feed rates and deeper cuts than any previous cutter. The availability of several different blades makes this cutter suitable for most core types. The hogger design also imparts less force as it evacuates and shreds scrap.

Usage CNC machining of honeycomb core

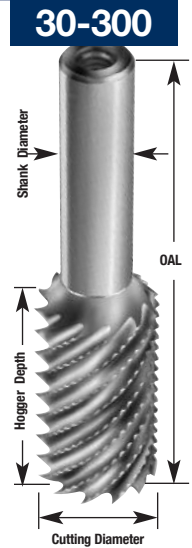
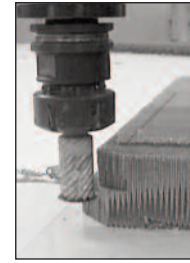

HONEYCOMB HOGGER					CUTTING BLADE OPTIONS						SPARE PARTS	
Part #	Cutting Diameter	Hogger Depth	Shank DIA	OAL	Blade Diameter	Solid Carbide	Solid Carbide w/Teeth	Diamond Plated	HSS Saw	Adapter Ring	Screw	
30-310	7/8 (22.22mm)	1 1/2	1/2	3 1/2	1 (25.4mm)	30-012	30-313	30-113	30-213	-	30-011-2	
30-315	1 1/4 (31.75mm)	1 1/2	1/2	3 1/2	1 1/2 (38.1mm)	30-014	30-314	30-114	30-214	30-020-3	30-020-4	
30-321	1 3/4 (44.45mm)	1 1/2	1/2	3 1/2	2 (50.8mm)	30-022	30-322	30-122	30-222	30-020-3	30-020-4	
30-331	2 3/4 (69.85mm)	1	1/2	3 1/2	3 (76.2mm)	30-032	30-332	30-132	30-232	30-030-3	30-030-4	
30-341	3 3/4 (95.25mm)	1	3/4	3 1/2	4 (101.6mm)	30-042	30-342	30-142	30-242	30-040-3	30-040-4	

See page 14 or 16 for Images of Cutting Blades

Reduced Weight Honeycomb Cutter

35% weight reduction has been designed into the larger diameter tools resulting in better performance on 3 or 5 axis machines. Part lifting and flagging have also been reduced due to the new tooth and flute design. Existing honeycomb blades will mount on these hoggers.

Usage CNC Machining of Honeycomb Core



HONEYCOMB HOGGER					CUTTING BLADE OPTIONS							SPARE PARTS	
Part #	Cutting Diameter	Hogger Depth	Shank DIA	OAL	Blade Diameter	HSS	HSS w/Teeth	Solid Carbide	Solid Carbide w/Teeth	Diamond Plated	HSS Saw	Adapter Ring	Screw
30-703	.345 (8.76mm)	1	1/2	3	3/8 (9.52mm)	30-016	30-316	-	-	-	-	-	HRD51646
30-705	.470 (11.93mm)	1	1/2	3	1/2 (12.7mm)	30-017	30-317	-	-	-	-	-	HRD51646
30-707	.720 (18.28mm)	1	1/2	3	3/4 (19.05mm)	-	-	30-015	30-318	-	-	-	30-011-2
30-710	.970 (24.63mm)	1	1/2	3	1 (25.4mm)	-	-	30-012	30-313	30-113	30-213	-	30-011-2
30-715	1.470 (37.33mm)	1	1/2	3	1 1/2 (38.10mm)	-	-	30-014	30-314	30-114	30-214	30-020-3	30-020-4
30-720	1.742 (44.24mm)	1	1/2	3	1.772 (45mm)	-	-	30-026	30-326	30-126 ¹	30-226 ¹	30-020-3	30-020-4
30-725	1.970 (50.03mm)	1	5/8	3	2 (50.8mm)	-	-	30-022	30-322	30-122	30-222	30-020-3	30-020-4
30-730	2.450 (62.23mm)	1	5/8	3	2.480 (63mm)	-	-	30-036	30-336	30-136	30-236	30-030-3	30-030-4
30-735	2.970 (75.43mm)	1	3/4	3	3 (76.20mm)	-	-	30-032	30-332	30-132	30-232	30-030-3	30-030-4
30-740	3.970 (100.83mm)	1	3/4	3	4 (101.6mm)	-	-	30-042	30-342	30-142	30-242	30-040-3	30-040-4

¹ = 50mm diameter honecomb blade

See page 14 or 16 for Images of Cutting Blades

31-000

High Speed Steel Cutter



Designed primarily for use on aluminum core, offering the versatility of smaller sizes for use on hand-held machines in field or maintenance type repairs. This cutter offers the strength of an integral shank and blade that has an edge sharpness unattainable with any other material. This sharpness and the relieved bottom yield part surfaces that require a minimum of preparation before bonding operation.

Usage Aluminum Core

Part Number	Cutting DIA	SHK DIA	OAL
31-010	1/2	1/4	2-1/16
31-015	3/4	1/4	2-3/32
31-020	1	1/4	2-1/8
31-025	1-1/2	1/2	2-1/4
31-030	2	1/2	2-3/4
31-040	3	1/2	2-15/16

Core Type	Rating
Aluminum, Lo Density (Less than 5#/cuft)	1
Aluminum, Hi Density (More than 5#/cuft)	2
Paper	2
Paper, Reinforced	N
Fiberglass	N
Phenolic	N
Polycarbonate	N
Aramid	N

1 - Excellent, 2 - Good, N - Not Recommended

31-100

High Speed Steel Honeycomb Cutter With Teeth



Small diameter honeycomb cutters were designed to offer the flexibility of cutting small slots or pockets in honeycomb core. The tools are versatile and can be used on CNC machines or hand held machines for field or maintenance type repairs.

Usage For contouring, carving, pocketing, and chamfer cuts

Part Number	Cutting DIA	SHK DIA	OAL
31-102TCN	3/8	1/4	3
31-104TCN	1/2	1/4	3
31-106TCN	5/8	1/4	3
31-108TCN	3/4	1/4	3

Cutting Blades for Cutters and Hogs

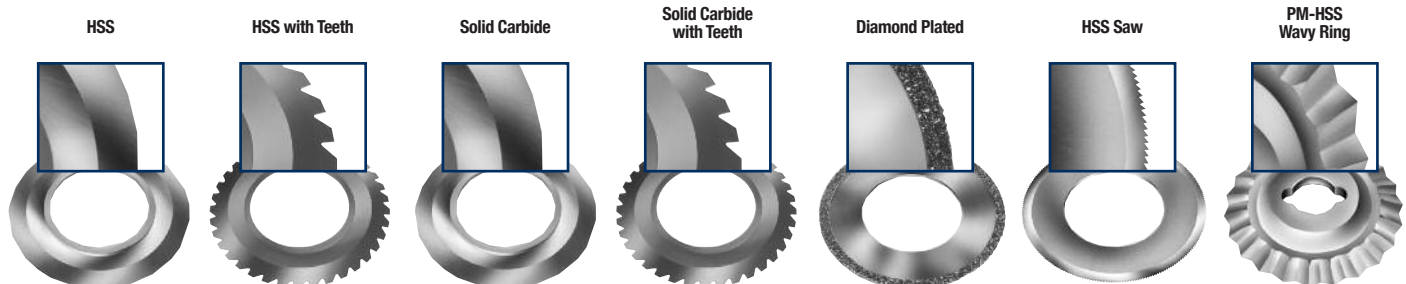

High Speed Steel Hogger

These cutters are specifically designed for fast (low force) removal of excess core followed by a final finish pass to obtain excellent finishes with one tool. These cutters enable cuts of up to .60" depths in a single pass. The availability of several different blades makes this cutter suitable for most core types. All assemblies require a shank, hogger and blade.

Usage Fast removal of excess core



HONEYCOMB HOGGER			SHANK		CUTTING BLADE OPTIONS					SPARE PARTS	
Part #	Cutting Diameter	Hogger Depth	Part #	Shank DIA	Blade Diameter	Solid Carbide	Diamond Plated	HSS Wavy Ring	HSS Saw	Adapter Ring	Screw
32-022	1.732 (44mm)	.629 (16mm)	32-021	1/2	1.771 (45mm)	32-026	-	32-023	-	-	-
					1.968 (50mm)	-	32-029*	-	32-027*	32-028	-
32-032	2.421 (61.5mm)	.629 (16mm)	32-031	1/2	2.480 (63mm)	32-036	-	32-033	-	-	-
					2.952 (75mm)	-	32-039*	-	32-037*	32-038	-

32-100 - Wrench for 32-000 Tools

See page 14 or 16 for Images of Cutting Blades

* Requires Adapter Ring

HSS Three Piece Honeycomb Hogger (Coated)

Designed with more aggressive hogger geometry than the 32-000 series. Both the hogger and blade with teeth have a fine tooth grind pattern resulting in increased feed rates and improved part finish. All hogs and blades are coated with a ZRN coating for increase in tool life. All hogger assemblies require a shank, a hogger and a blade. This design also allows the tool to be use without the hogger by replacing the hogger with a spacer.

Usage Fast removal of excess core

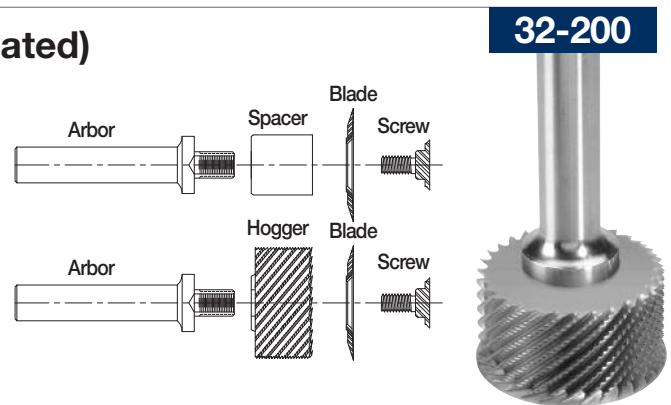

HONEYCOMB HOGGER			SHANK			CUTTING BLADE OPTIONS			SPARE PARTS	
Part #	Cutting Diameter	Hogger Depth	Part #	Shank DIA	OAL	Blade Diameter	Solid Carbide	Solid Carbide w/Teeth	Spacer	Retaining Screw
32-210	0.94" (23.88mm)	1" (25.4mm)	32-221	3/8"	4"	1" (25.4mm)	32-412	32-512	32-221-3	32-221-4
32-225	1.94" (49.28mm)	1" (25.4mm)	32-231	1/2"	4"	2" (50.8mm)	32-422	32-522	32-231-3	32-231-4
			32-241	5/8"	4"					
32-235	2.94" (74.68mm)	1" (25.4mm)	32-231	1/2"	4"	3" (76.2mm)	32-432	32-532	32-231-3	32-231-4
			32-241	5/8"	4"					
32-220	1.72" (43.69mm)	1" (25.4mm)	32-231	1/2"	4"	1.77" (45mm)	32-426	32-526	32-231-3	32-231-4
			32-241	5/8"	4"					
32-230	2.42" (61.47mm)	1" (25.4mm)	32-231	1/2"	4"	2.48" (63mm)	32-436	32-536	32-231-3	32-231-4
			32-241	5/8"	4"					

32-201 - Wrench for 32-200 Tools (for Shank Diameters 1/2" & 5/8")

32-202 - Wrench for 32-200 Tools (for Shank Diameters 3/8")

See page 14 or 16 for Images of Cutting Blades

34-000

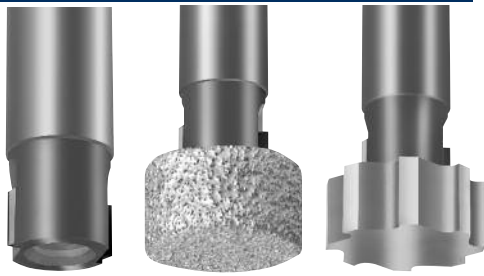

Arbor

Diamond Grit

HSS

Aircraft Panel Tools

This modular tool is designed to produce slots in composite panels so potting compound can be applied to strengthen the edge. This tool consists of a PCD arbor which accepts a diamond grit or HSS under cutting tool to be screwed into it.

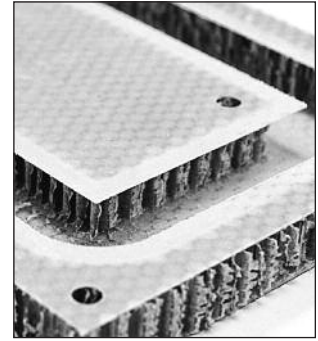

Usage HCC Panels

Part Number	Cutting DIA	Flute LGTH	SHK DIA	
34-008	1/2	-	1/2	Arbor (non-cutting)
34-010	1/2	1/4	1/2	PCD Arbor
34-022	7/8	0.130	n/a	Diamond Grit Cutter
34-024	7/8	0.250	n/a	Diamond Grit Cutter
34-026	7/8	0.380	n/a	Diamond Grit Cutter
34-028	7/8	0.500	n/a	Diamond Grit Cutter

Part Number	Cutting DIA	Flute LGTH	SHK DIA	
34-030	7/8	0.630	n/a	Diamond Grit Cutter
34-042	7/8	0.130	n/a	HSS Cutter
34-044	7/8	0.250	n/a	HSS Cutter
34-046	7/8	0.380	n/a	HSS Cutter
34-048	7/8	0.500	n/a	HSS Cutter
34-050	7/8	0.630	n/a	HSS Cutter

34-100



Potted Fastener Tools (Coated)

The tool was designed to eliminate the inconsistencies in producing the holes in aircraft interior panels to mount potted, glued in, fasteners. This tool for composite panels will plunge and shred the HCC. In aluminum panels an entry hole is required but the HCC shred is clean and effective. Coated for increased tool life.

Usage Honeycomb Panel

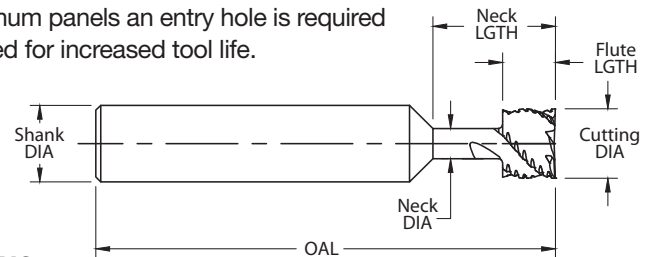

METRIC

Part Number	Cutting DIA	Flute LGTH	SHK DIA	Neck DIA	Neck Length	OAL
34-107	0.45	0.13	1/2	0.18	0.80	3
34-109	0.45	0.25	1/2	0.18	0.80	3
34-111	0.45	0.38	1/2	0.18	0.80	3
34-113	0.45	0.50	1/2	0.18	0.80	3
34-115	0.50	0.13	1/2	0.19	0.80	3
34-117	0.50	0.25	1/2	0.19	0.80	3
34-119	0.50	0.38	1/2	0.19	0.80	3
34-121	0.50	0.50	1/2	0.19	0.80	3
34-123	0.56	0.13	1/2	0.22	0.80	3
34-125	0.56	0.25	1/2	0.22	0.80	3
34-127	0.56	0.38	1/2	0.22	0.80	3
34-129	0.56	0.50	1/2	0.22	0.80	3
34-131	0.63	0.13	5/8	0.25	0.80	3
34-133	0.63	0.25	5/8	0.25	0.80	3
34-135	0.63	0.38	5/8	0.25	0.80	3
34-137	0.63	0.50	5/8	0.25	0.80	3

Part Number	Cutting DIA	Flute LGTH	SHK DIA	Neck DIA	Neck Length	OAL
34-106	11.51mm	3.30mm	12mm	4.57mm	20.32mm	76mm
34-108	11.51mm	6.35mm	12mm	4.57mm	20.32mm	76mm
34-110	11.51mm	9.65mm	12mm	4.57mm	20.32mm	76mm
34-112	11.51mm	12.70mm	12mm	4.57mm	20.32mm	76mm
34-114	12.70mm	3.30mm	12mm	4.83mm	20.32mm	76mm
34-116	12.70mm	6.35mm	12mm	4.83mm	20.32mm	76mm
34-118	12.70mm	9.65mm	12mm	4.83mm	20.32mm	76mm
34-120	12.70mm	12.70mm	12mm	4.83mm	20.32mm	76mm
34-122	14.29mm	3.30mm	12mm	5.59mm	20.32mm	76mm
34-124	14.29mm	6.35mm	12mm	5.59mm	20.32mm	76mm
34-126	14.29mm	9.65mm	12mm	5.59mm	20.32mm	76mm
34-128	14.29mm	12.70mm	12mm	5.59mm	20.32mm	76mm
34-130	16mm	3.30mm	16mm	6.35mm	20.32mm	76mm
34-132	16mm	6.35mm	16mm	6.35mm	20.32mm	76mm
34-134	16mm	9.65mm	16mm	6.35mm	20.32mm	76mm
34-136	16mm	12.70mm	16mm	6.35mm	20.32mm	76mm

Honeycomb Technical Data Sheets

29-000	HONEYCOMB CORE	ALUMINUM		NOMEX		PAPER	
	Part #	RPM	Feed Rate	RPM	Feed Rate	RPM	Feed Rate
	29-003 (1/4")	500-10,000	100 IPM	500-10,000	120 IPM	500-10,000	120 IPM
	29-006 (3/8")	500-10,000	100 IPM	500-10,000	120 IPM	500-10,000	120 IPM
	29-009 (1/2")	500-10,000	100 IPM	500-10,000	120 IPM	500-10,000	120 IPM
	29-012 (5/8")	500-10,000	100 IPM	500-10,000	120 IPM	500-10,000	120 IPM
	29-015 (3/4")	500-10,000	100 IPM	500-10,000	120 IPM	500-10,000	120 IPM

29-050	SPINDLE SPEED			CORE TYPE	29-100	SPINDLE SPEED		
	DIA	Max RPM	Feed Rate			DIA	Max RPM	Feed Rate
	1/4	25,000	NR	Aluminum, less than 5#/cuft		1/4	25,000	100
	3/8	25,000	NR	Aluminum, More than 5#/cuft		3/8	25,000	100
	1/2	25,000	800	Paper based		1/2	25,000	400
	3/4	25,000	800	Paper, based w/Fiber Reinforcement		3/4	25,000	800
	1	25,000	800	Fiberglass				
	1-1/2	18,000	800	Phenolic				
	1-3/4	18,000	NR	Carbon Fiber				
	2	16,500	100	Aramid, less than 5#/cuft				
	2-1/2	15,000	100	Aramid, More than 5#/cuft				
	3	14,000						
	4	12,000						

30-000/ 30-300 30-700 32-200	FEEDS & SPEEDS	FEED RATES				SPINDLE SPEED	
	Core Type	Solid Carbide	Solid Carbide w/Teeth	Diamond Saw	HSS	DIA	MAX RPM
	Aluminum, Less than 5#/cuft	100	100	NR	150	1/4	25,000
	Aluminum, More than 5#/cuft	100	100	NR	100	3/8	25,000
	Paper based	400	400	NR	250	1/2	25,000
	Paper, based with Fiber Reinforcement	800	800	400	150	3/4	25,000
	Fiberglass	600	600	600	NR	1	25,000
	Phenolic	200	200	400	NR	1-1/2	18,000
	Carbon Fiber	NR	NR	800	NR	1-3/4	18,000
	Aramid, Less than 5#/cuft	800	800	400	150	2	16,500
	Aramid, More than 5#/cuft	800	800	400	NR	2-1/2	15,000
						3	14,000
						4	12,000

Note: 30-300 assembly requires one (1) hogger and one (1) blade

31-000/ 32-000	FEEDS & SPEEDS	FEED RATES						SPINDLE SPEED	
	Core Type	Solid Carbide	Diamond Plated	HSS Saw	HSS Wavy	HSS (31-000)	HSS (31-100)	DIA	MAX RPM
	Aluminum, Less than 5#/cuft	100	NR	150	100	100-140	90-140	3/8	25,000
	Aluminum, More than 5#/cuft	100	NR	100	100	70	70	1/2	25,000
	Paper based	300	NR	200	300	50	50	3/4	25,000
	Paper, based w/Fiber Reinforcement	400	300	600	300	100-150	100-150	1	25,000
	Fiberglass	NR	600	NR	NR	NR	NR	1-1/2	25,000
	Phenolic	NR	600	NR	NR	NR	NR	1-3/4	25,000
	Carbon Fiber	NR	800	NR	NR	NR	NR	2	18,000
	Aramid, Less than 5#/cuft	200	NR	150	200	100-150	100-150	2-1/2	18,000
	Aramid, More than 5#/cuft	200	400	NR	NR	NR	NR	3	18,000

34-000	Core Type	Cutter	RPM	Feed Rate	Cut Direction
	Fiberglass panels with paper core (Nomex)	Diamond Grit	18,000	220 lpm	Conventional
	Aluminum panels with aluminum core	HSS Saw	16,000	120 lpm	Conventional

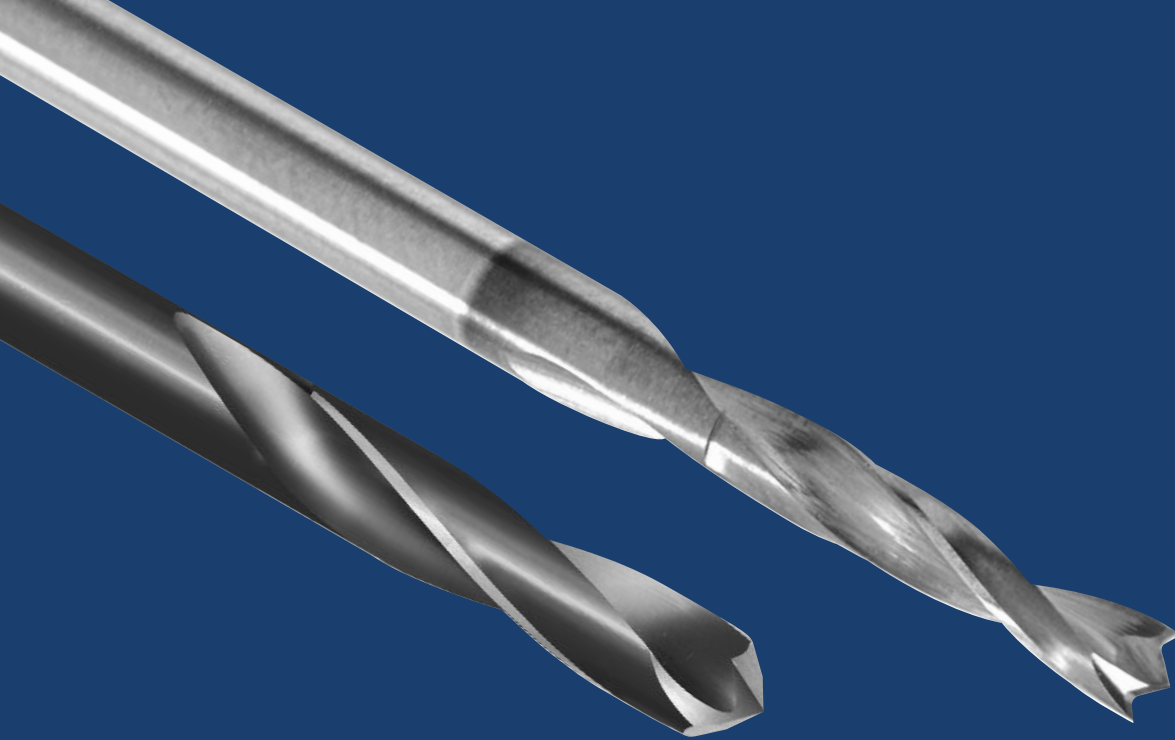

Drills

Composite Cutting Tools

Drilling holes in composite materials is just as important as machining. In fact, 60% of all rejected parts are due to drilled holes. The reason for the rejection is delamination of material caused by excessive pressure created while drilling. LMT Onsrud offers many styles of solid carbide and PCD drills based on the material, application and accuracy of the hole being produced.

LMT Onsrud offers a wide variety of standard drills, but realize that many special sizes are required. Quote request forms have been made in the most popular drill styles to make the quote request process efficient.

Solid Carbide 8 Facet Drill

67-800

Designed to reduce cutting forces and eliminating delamination when exiting the material.

Usage Composites, Carbon fiber, mechanical plastics, and fiber reinforced plastics

What is an 8 Facet Drill?

An 8 facet drill consists of 4 cutting edges with 2 facets per cutting edge. These facets consist of the lip relief and the lip clearance angle.

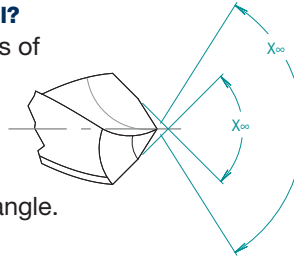

FRACTIONAL DRILLS

Part Number	Cutting DIA	Flute LGTH	SHK DIA	OAL
67-807	1/8 (0.1250)	1-1/4	0.125	2-1/4
67-808	9/64 (0.1406)	1-3/8	0.140	2-1/2
67-809	5/32 (0.1563)	1-3/8	0.156	2-1/2
67-810	11/64 (0.1719)	1-5/8	0.172	2-3/4
67-811	3/16 (0.1875)	1-5/8	0.188	2-3/4
67-812	13/64 (0.2013)	1-3/4	0.203	3
67-813	7/32 (0.2188)	1-3/4	0.219	3
67-814	15/64 (0.2344)	2	0.234	3-1/4
67-815	1/4 (0.2500)	2	0.250	3-1/4
67-816	17/64 (0.2656)	2-1/8	0.266	3-1/2
67-817	9/32 (0.2813)	2-1/8	0.281	3-1/2
67-818	19/64 (0.2969)	2-3/8	0.297	3-3/4
67-819	5/16 (0.3125)	2-3/8	0.313	3-3/4
67-820	21/64 (0.3281)	2-1/2	0.328	4
67-821	11/32 (0.3438)	2-1/2	0.344	4
67-822	23/64 (0.3594)	2-1/2	0.359	4
67-823	3/8 (0.3750)	2-3/4	0.375	4-1/4
67-824	25/64 (0.3906)	2-7/8	0.391	4-1/2
67-825	13/32 (0.4063)	2-7/8	0.406	4-1/2
67-826	27/64 (0.4219)	2-7/8	0.422	4-1/2
67-827	7/16 (0.4375)	2-7/8	0.438	4-1/2
67-828	29/64 (0.4531)	3	0.453	4-3/4
67-829	15/32 (0.4688)	3	0.469	4-3/4
67-830	31/64 (0.4844)	3	0.484	4-3/4
67-831	1/2 (0.5000)	3	0.500	4-3/4

LETTER DRILLS (CONT.)

Part Number	Cutting DIA	Flute LGTH	SHK DIA	OAL
67-850	A (0.2340)	2	0.234	3-1/4
67-851	B (0.2380)	2	0.238	3-1/4
67-852	C (0.2420)	2	0.242	3-1/4
67-853	D (0.2460)	2	0.246	3-1/4
67-854	E (0.2500)	2	0.250	3-1/4
67-855	F (0.2570)	2	0.257	3-1/4
67-856	G (0.2610)	2-1/8	0.261	3-1/2
67-857	H (0.2660)	2-1/8	0.266	3-1/2
67-858	I (0.2720)	2-1/8	0.272	3-1/2

LETTER DRILLS (CONT.)

Part Number	Cutting DIA	Flute LGTH	SHK DIA	OAL
67-859	J (0.2770)	2-1/8	0.277	3-1/2
67-860	K (0.2810)	2-1/8	0.281	3-1/2
67-861	L (0.2910)	2-1/8	0.291	3-1/2
67-862	M (0.2950)	2-3/8	0.295	3-3/4
67-863	N (0.3020)	2-3/8	0.302	3-3/4
67-864	O (0.3160)	2-3/8	0.316	3-3/4
67-865	P (0.3230)	2-3/8	0.323	3-3/4
67-866	Q (0.3320)	2-1/2	0.332	4
67-867	R (0.3390)	2-1/2	0.339	4
67-868	S (0.3480)	2-1/2	0.348	4
67-869	T (0.3580)	2-1/2	0.358	4
67-870	U (0.3680)	2-3/4	0.368	4-1/4
67-871	V (0.3770)	2-3/4	0.377	4-1/4
67-872	W (0.3860)	2-7/8	0.386	4-1/2
67-873	X (0.3970)	2-7/8	0.397	4-1/2
67-874	Y (0.4040)	2-7/8	0.404	4-1/2
67-875	Z (0.4130)	2-7/8	0.413	4-1/2

NUMBER DRILLS

Part Number	Cutting DIA	Flute LGTH	SHK DIA	OAL
67-876	1 (0.2280)	1-3/4	0.228	3
67-877	2 (0.2210)	1-3/4	0.221	3
67-878	3 (0.2130)	1-3/4	0.213	3
67-879	4 (0.2090)	1-3/4	0.209	3
67-880	5 (0.2055)	1-3/4	0.206	3
67-881	6 (0.2040)	1-3/4	0.204	3
67-882	7 (0.2010)	1-3/4	0.201	3
67-883	8 (0.1990)	1-3/4	0.199	3
67-884	9 (0.1960)	1-3/4	0.196	3
67-885	10 (0.1935)	1-5/8	0.194	2-3/4
67-886	11 (0.1910)	1-5/8	0.191	2-3/4
67-887	12 (0.1890)	1-5/8	0.189	2-3/4
67-888	13 (0.1850)	1-5/8	0.185	2-3/4
67-889	14 (0.1820)	1-5/8	0.182	2-3/4
67-890	15 (0.1800)	1-5/8	0.180	2-3/4
67-891	16 (0.1770)	1-5/8	0.177	2-3/4
67-892	17 (0.1730)	1-5/8	0.173	2-3/4

NUMBER DRILLS (CONT.)

Part Number	Cutting DIA	Flute LGTH	SHK DIA	OAL
67-893	18 (0.1695)	1-5/8	0.170	2-3/4
67-894	19 (0.1660)	1-5/8	0.166	2-3/4
67-895	20 (0.1610)	1-3/8	0.161	2-1/2
67-896	21 (0.1590)	1-3/8	0.159	2-1/2
67-897	22 (0.1570)	1-3/8	0.157	2-1/2
67-898	23 (0.1540)	1-3/8	0.154	2-1/2
67-899	24 (0.1520)	1-3/8	0.152	2-1/2
67-900	25 (0.1495)	1-3/8	0.150	2-1/2
67-901	26 (0.1470)	1-3/8	0.147	2-1/2
67-902	27 (0.1440)	1-3/8	0.144	2-1/2
67-903	28 (0.1405)	1-3/8	0.141	2-1/2
67-904	29 (0.1360)	1-3/8	0.136	2-1/2
67-905	30 (0.1285)	1-1/4	0.129	2-1/4
67-906	31 (0.1200)	1-1/4	0.120	2-1/4

METRIC DRILLS

Part Number	Cutting DIA	Flute LGTH	SHK DIA	OAL
67-961	3.00 (0.1181)	32	3.00	57
67-962	3.50 (0.1378)	35	3.50	64
67-963	4.00 (0.1575)	35	4.00	64
67-964	4.50 (0.1772)	41	4.50	70
67-965	5.00 (0.1969)	44	5.00	76
67-966	5.50 (0.2165)	44	5.50	76
67-967	6.00 (0.2362)	51	6.00	83
67-968	6.50 (0.2559)	51	6.50	83
67-969	7.00 (0.2756)	57	7.00	89
67-970	7.50 (0.2953)	60	7.50	95
67-971	8.00 (0.3150)	60	8.00	95
67-972	8.50 (0.3346)	64	8.50	102
67-973	9.00 (0.3543)	64	9.00	102
67-974	9.50 (0.3740)	70	9.50	108
67-975	10.00 (0.3937)	73	10.00	114
67-976	10.50 (0.4134)	73	10.50	114
67-977	11.00 (0.4331)	73	11.00	114
67-978	11.50 (0.4528)	76	11.50	121
67-979	12.00 (0.4724)	76	12.00	121

68-900**PCD 8 Facet Drills**

The PCD 8 facet drill works well in composite material where long tool life and a delamination free hole is required. The drill diameters are oversize allowing for aircraft fasteners to extend through the holes.

Usage Composites

Part Number	Cutting DIA	Flute LGTH	SHK DIA	OAL
68-902	0.100	1	1/4	3
68-904	0.129	1	1/4	3
68-908	0.147	1	1/4	3
68-910	0.192	1	1/4	3
68-914	0.251	1	1/4	3
68-918	0.313	1	5/16	3
68-922	0.376	1	3/8	3
68-926	0.502	1	1/2	3

86-100**Diamond Film Coated Solid Carbide Parabolic Drill**

Designed to produce a clean, delamination free hole in composite materials. The diamond film coated (CVD) parabolic drill is an economical solution to PCD composite drills.

Usage Carbon fiber and other composite materials

Part Number	Cutting DIA	Flute LGTH	SHK DIA	OAL
86-102	0.100	1	1/4	3
86-106	0.129	1	1/4	3
86-110	0.147	1	1/4	3
86-114	0.192	1	1/4	3
86-118	0.251	1	1/4	3
86-122	0.313	1	5/16	3
86-126	0.376	1	3/8	3
86-130	0.502	1	1/2	3

Solid Carbide CFRP Drill (Coated)

85-800

The CFRP drill is designed to ensure hole quality and diameter. The “W” point of the drill centers the drill to let the peripheral cutting edges shear the material producing a clean, tight tolerance hole without fraying or delamination. The drills are coated with a Diamond Like Carbon (DLC).

Usage Carbon Fiber Reinforced Plastics, Kevlar® and Composites



NEW

FRACTIONAL DRILLS

Part Number	Cutting DIA	Flute LGTH	SHK DIA	OAL
85-807	1/8 (0.1250)	0.500	1/8	3
85-808	9/64 (0.1406)	0.500	3/16	3
85-809	5/32 (0.1563)	0.500	3/16	3
85-810	11/64 (0.1719)	0.500	3/16	3
85-811	3/16 (0.1875)	0.500	3/16	3
85-812	13/64 (0.2031)	0.500	1/4	3
85-813	7/32 (0.2188)	0.500	1/4	3
85-814	15/64 (0.2344)	0.500	1/4	3
85-815	1/4 (0.2500)	0.500	1/4	3
85-816	17/64 (0.2656)	0.500	5/16	3
85-817	9/32 (0.2813)	0.500	5/16	3
85-818	19/64 (0.2969)	0.500	5/16	3
85-819	5/16 (0.3125)	0.500	5/16	3
85-820	21/64 (0.3281)	0.500	3/8	3
85-821	11/32 (0.3438)	0.500	3/8	3
85-822	23/64 (0.3594)	0.500	3/8	3
85-823	3/8 (0.3750)	0.500	3/8	3
85-827	7/16 (0.4375)	0.500	7/16	3
85-831	1/2 (0.5000)	0.500	1/2	3

METRIC DRILLS

Part Number	Cutting DIA	Flute LGTH	SHK DIA	OAL
85-961	3.00 (0.1181)	12.000	3	76
85-963	4.00 (0.1575)	12.000	4	76
85-965	5.00 (0.1969)	12.000	5	76
85-967	6.00 (0.2362)	12.000	6	76
85-971	8.00 (0.3150)	12.000	8	76
85-975	10.00 (0.3937)	12.000	10	76
85-979	12.00 (0.4724)	12.000	12	76

NUMBER DRILLS

Part Number	Cutting DIA	Flute LGTH	SHK DIA	OAL
85-876	1 (0.2280)	0.500	1/4	3
85-877	2 (0.2210)	0.500	1/4	3
85-878	3 (0.2130)	0.500	1/4	3
85-879	4 (0.2090)	0.500	1/4	3
85-880	5 (0.2055)	0.500	1/4	3
85-881	6 (0.2040)	0.500	1/4	3
85-882	7 (0.2010)	0.500	1/4	3
85-883	8 (0.1990)	0.500	1/4	3
85-884	9 (0.1960)	0.500	1/4	3
85-885	10 (0.1935)	0.500	1/4	3
85-886	11 (0.1910)	0.500	1/4	3
85-887	12 (0.1890)	0.500	1/4	3
85-888	13 (0.1850)	0.500	3/16	3
85-889	14 (0.1820)	0.500	3/16	3
85-890	15 (0.1800)	0.500	3/16	3
85-891	16 (0.1770)	0.500	3/16	3
85-892	17 (0.1730)	0.500	3/16	3
85-893	18 (0.1695)	0.500	3/16	3
85-894	19 (0.1660)	0.500	3/16	3
85-895	20 (0.1610)	0.500	3/16	3
85-896	21 (0.1590)	0.500	3/16	3

NUMBER DRILLS (CONT.)

Part Number	Cutting DIA	Flute LGTH	SHK DIA	OAL
85-897	22 (0.1570)	0.500	3/16	3
85-898	23 (0.1540)	0.500	5/32	3
85-899	24 (0.1520)	0.500	5/32	3
85-900	25 (0.1495)	0.500	5/32	3
85-901	26 (0.1470)	0.500	5/32	3
85-902	27 (0.1440)	0.500	5/32	3
85-903	28 (0.1405)	0.500	5/32	3
85-904	29 (0.1360)	0.500	5/32	3
85-905	30 (0.1285)	0.500	5/32	3
85-906	31 (0.1200)	0.500	1/8	2-1/2
85-907	32 (0.1160)	0.500	1/8	2-1/2
85-908	33 (0.1130)	0.500	1/8	2-1/2
85-909	34 (0.1110)	0.500	1/8	2-1/2
85-910	35 (0.1100)	0.500	1/8	2-1/2
85-911	36 (0.1065)	0.500	1/8	2-1/2
85-912	37 (0.1040)	0.500	1/8	2-1/2
85-913	38 (0.1015)	0.500	1/8	2-1/2
85-914	39 (0.0995)	0.500	1/8	2-1/2
85-915	40 (0.0980)	0.500	1/8	2-1/2
85-916	41 (0.0960)	0.500	1/8	2-1/2



Composite Cutting Data

APPLICATION	GOOD	BETTER	BEST
Finishing			54-200
Honeycomb	67-300	32-000	30-300
CFRP	66-900	66-800	68-300
G10/G11 Fiberglass	56-000P	67-000	54-200
Fiberglass	67-000	67-400	67-200
Phenolic	53-000P	67-200	67-220
Single Pass	56-000P	67-250	68-000

DEPTH OF CUT: 1 x D Use recommended chip load
 2 x D Reduce chip load by 25%
 3 x D Reduce chip load by 50%

CHIP LOAD PER TOOTH

Cutting Edge Diameter															
Series	Cut	1/16	3/32	1/8	5/32	3/16	7/32	1/4	5/16	3/8	7/16	1/2	9/16	5/8	3/4
54-200	1 x D			.002-.004		.002-.004		.002-.004		.003-.006		.005-.010			
56-000P	1 x D			.002-.004		.002-.004		.004-.006		.004-.006		.004-.006			
63-000	1 x D			.003-.005		.003-.005		.003-.005	.004-.006			.005-.007			
66-700	1 x D							.0005-.001		.0006-.001		.0008-.0015			
66-800	1 x D							.001-.002		.002-.003		.003-.004			
66-900	1 x D			.002-.004		.002-.004		.004-.006		.004-.006		.006-.008			
67-000	1 x D							.004-.006		.004-.006		.004-.006			
67-200	1 x D									.002-.010		.002-.010			
67-220	1 x D									.001-.002		.001-.002			
67-250	1 x D			.002-.004				.004-.006		.004-.006					
67-300	1 x D							.004-.006		.006-.008		.010-.012			
67-400	1 x D			.002-.004				.004-.006		.004-.006		.004-.006			
67-500	1 x D			.001-.003		.001-.003		.002-.004	.002-.004	.003-.005		.004-.006			
68-000	1 x D							.004-.006		.004-.006		.004-.006			.008-.010
68-200	1 x D							.0005-.001		.001-.002		.001-.002			
68-300	1 x D									.001-.002		.001-.002			.004-.006

NOTE: Spindle RPM's generally range from 9,000 - 12,000 when cutting composite materials

FORMULAS: Chip Load = Feed Rate / (RPM x # of cutting edges)
 Feed Rate (IPM) = RPM x # of cutting edges x chip load
 Speed (RPM) = Feed Rate / (# of cutting edges x chip load)
 SFM = 3.14 x Diameter x RPM / 12

DEFINITIONS: IPM = Inches Per Minute
 IPR = Inches Per Revolution

Drilling Cutting Data

Drill Diameter															
Series		SFM	3mm	1/8	3/16	5mm	6mm	1/4	5/16	8mm	3/8	10mm	7/16	12mm	1/2
67-800	Composites	230	.001-.002	.001-.003	.001-.003	.001-.003	.002-.004	.002-.004	.002-.004	.002-.004	.003-.005	.003-.005	.003-.005	.003-.005	.003-.005
68-900	Composites	230	0.001	0.001		0.001		0.0015		0.0015	0.0015				0.0015
85-800	Composites	230		0.0005	0.0005			0.001	0.001		0.001		0.001		0.001
86-100	Composites	165		0.001		0.001		0.0015		0.0015	0.0015				0.0015

FORMULAS: RPM = (3.82 x SFM) / tool dia.
 Feedrate (IPM) = RPM x IPR
 SFM = 3.14 x Diameter x RPM / 12

DEFINITIONS:
 IPM = Inches Per Minute
 IPR = Inches Per Revolution

SOLID CARBIDE 8 FACET DRILL OR CFRP DRILL QUOTE REQUEST FORM

1081 S. Northpoint Blvd. • Waukegan, Illinois 60085 • Phone (847) 362-1560 • Fax (800) 557-6720 • www.onsrud.com

Designed to reduce cutting forces and eliminating delamination when exiting the material.

Usage: CP • Material: Composites

END USER INFORMATION

Company _____
 Contact _____
 Address _____

 Phone _____
 Fax _____
 Email _____

DISTRIBUTOR INFORMATION

Distributor _____
 Contact _____
 Phone _____
 Fax _____
 Email _____

CFRP DRILL

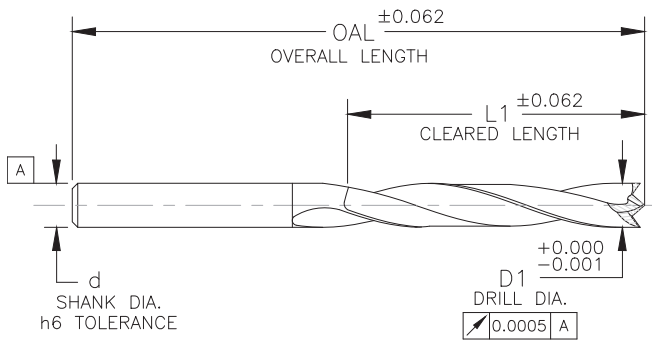

8 FACET DRILL

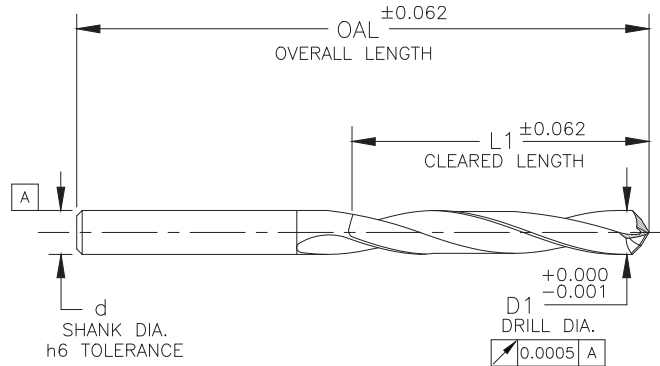

TOOL DIMENSIONS

D1 _____
 L1 _____
 d _____
 OAL _____

SPECIAL TOLERANCES

8 Facet Drill CFRP Drill

Material(s) Cut _____

Hardness _____

Quantity Breaks _____
 (Min. 6 pieces)

Coating _____

PCD 8 FACET DRILL QUOTE REQUEST FORM

1081 S. Northpoint Blvd. • Waukegan, Illinois 60085 • Phone (847) 362-1560 • Fax (800) 557-6720 • www.onsrud.com

The PCD 8 facet drill works well in composite materials where long tool life and delamination free holes are required.

Usage: CP • Material: Composites

END USER INFORMATION

Company _____
 Contact _____
 Address _____

 Phone _____
 Fax _____
 Email _____

DISTRIBUTOR INFORMATION

Distributor _____
 Contact _____
 Phone _____
 Fax _____
 Email _____

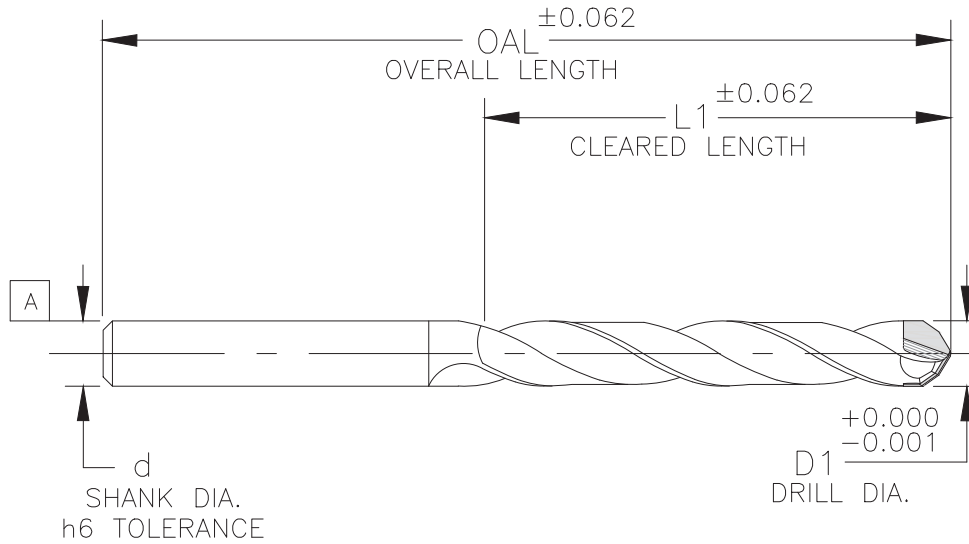

TOOL DIMENSIONS

D1 _____
 L1 _____
 d _____
 OAL _____

SPECIAL TOLERANCES

Material(s) Cut _____

Hardness _____

Quantity Breaks _____
 (Min. 6 pieces)

SOLID CARBIDE DFC PARABOLIC DRILL QUOTE REQUEST FORM

1081 S. Northpoint Blvd. • Waukegan, Illinois 60085 • Phone (847) 362-1560 • Fax (800) 557-6720 • www.onsrud.com

The parabolic drill is designed to produce a clean, delamination free hole in composite materials. The diamond film coated drill is an economical solution to PCD composite drills.

Usage: CP • Material: Composites

END USER INFORMATION

Company _____
 Contact _____
 Address _____

 Phone _____
 Fax _____
 Email _____

DISTRIBUTOR INFORMATION

Distributor _____
 Contact _____
 Phone _____
 Fax _____
 Email _____

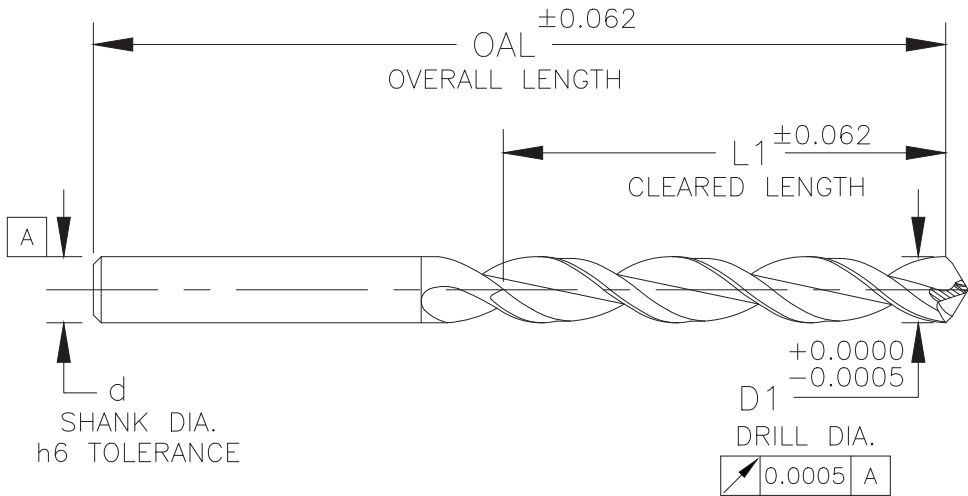

TOOL DIMENSIONS

SPECIAL TOLERANCES

D1 _____
 L1 _____
 d _____
 OAL _____

Material(s) Cut _____

Hardness _____

Quantity Breaks _____
 (Min. 6 pieces)

SOLID CARBIDE DOUBLE MARGIN PILOTED STEP DRILL QUOTE REQUEST FORM

1081 S. Northpoint Blvd. • Waukegan, Illinois 60085 • Phone (847) 362-1560 • Fax (800) 557-6720 • www.onsrud.com

Double margin piloted step drills are used to drill close tolerance holes (.003") in a single operation. The step diameter lowers the initial drilling force and can serve as a guide in pilot holes. They are designed for use in thin material that does not exceed 2 times the drill diameter.

Usage: CP • Material: Composites

END USER INFORMATION

DISTRIBUTOR INFORMATION

Company _____
 Contact _____
 Address _____

 Phone _____
 Fax _____
 Email _____

Distributor _____
 Contact _____
 Phone _____
 Fax _____
 Email _____

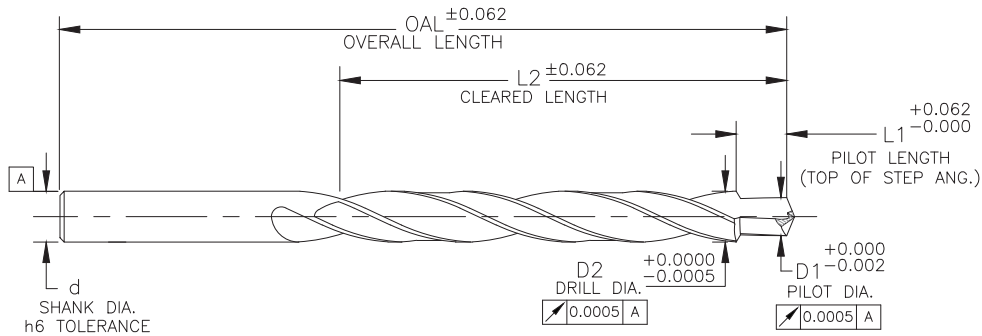

TOOL DIMENSIONS

SPECIAL TOLERANCES

D1 _____
 D2 _____
 L1 _____
 L2 _____
 d _____
 OAL _____

Material(s) Cut _____
 Hardness _____
 Quantity Breaks _____
 (Min. 6 pieces)
 Coating _____

SOLID CARBIDE PILOTED CORE DRILL QUOTE REQUEST FORM

1081 S. Northpoint Blvd. • Waukegan, Illinois 60085 • Phone (847) 362-1560 • Fax (800) 557-6720 • www.onsrud.com

Piloted Core drills are used to enlarge a drilled or punched hole. These drills are often used as a second pass tool in a multi-step drilling process and the pilot acts as a guide for the drill. This style of drill greatly increases the hole quality and accuracy compared to a 2 flute drill. With a proper set up, the core drill should produce a hole within +/- .002".

Usage: CP • Material: Composites

END USER INFORMATION

Company _____
 Contact _____
 Address _____

 Phone _____
 Fax _____
 Email _____

DISTRIBUTOR INFORMATION

Distributor _____
 Contact _____
 Phone _____
 Fax _____
 Email _____

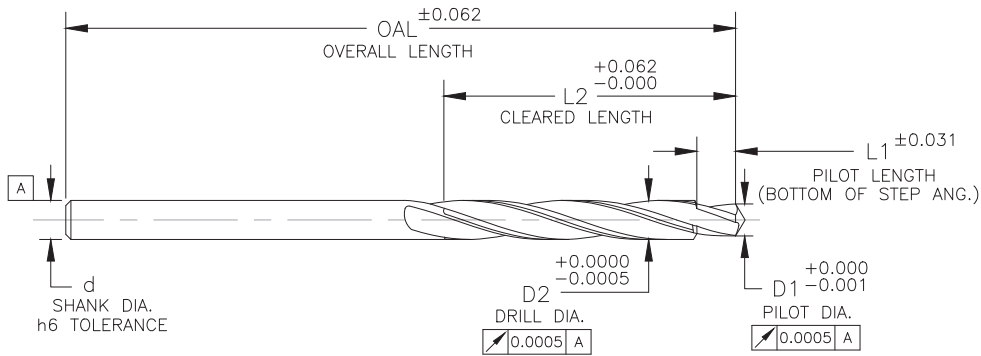

TOOL DIMENSIONS

SPECIAL TOLERANCES

D1 _____
 D2 _____
 L1 _____
 L2 _____
 d _____
 OAL _____

Material(s) Cut _____
 Hardness _____
 Quantity Breaks _____
 (Min. 6 pieces)
 Coating _____

SOLID CARBIDE ONE SHOT DRILL QUOTE REQUEST FORM

1081 S. Northpoint Blvd. • Waukegan, Illinois 60085 • Phone (847) 362-1560 • Fax (800) 557-6720 • www.onsrud.com

One shot drills are designed to drill and ream a hole in one pass. This style of drill is used on single sheet carbon fiber or woven or tape graphite epoxy.

Usage: CP • Material: Composites

END USER INFORMATION

DISTRIBUTOR INFORMATION

Company _____
 Contact _____
 Address _____

 Phone _____
 Fax _____
 Email _____

Distributor _____
 Contact _____
 Phone _____
 Fax _____
 Email _____

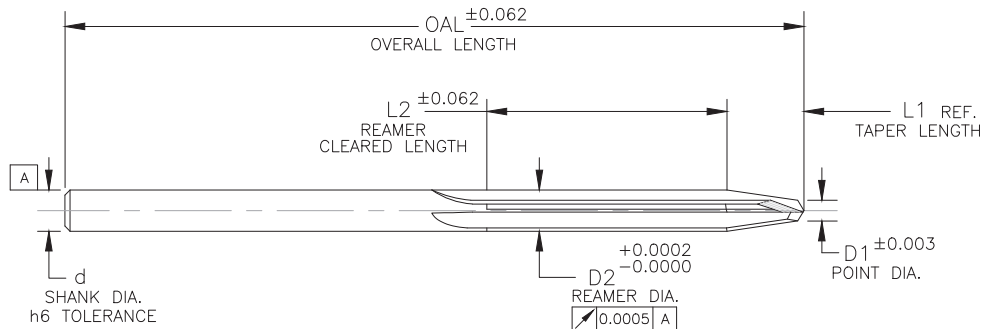

TOOL DIMENSIONS

SPECIAL TOLERANCES

D1 _____
 D2 _____
 L1 _____
 L2 _____
 d _____
 OAL _____

Material(s) Cut _____
 Hardness _____
 Quantity Breaks _____
 (Min. 6 pieces)
 Coating _____

SOLID CARBIDE DRIVMATIC® DRILL QUOTE REQUEST FORM

1081 S. Northpoint Blvd. • Waukegan, Illinois 60085 • Phone (847) 362-1560 • Fax (800) 557-6720 • www.onsrud.com

Drivmatic® Drills are specially designed for use in automatic fastening machines. They are produced to the exacting standards of the aerospace industry and available in three design configurations for the machining of Aluminum, Composite and Titanium.

Usage: CP • Material: Composites

END USER INFORMATION

Company _____
 Contact _____
 Address _____

 Phone _____
 Fax _____
 Email _____

DISTRIBUTOR INFORMATION

Distributor _____
 Contact _____
 Phone _____
 Fax _____
 Email _____

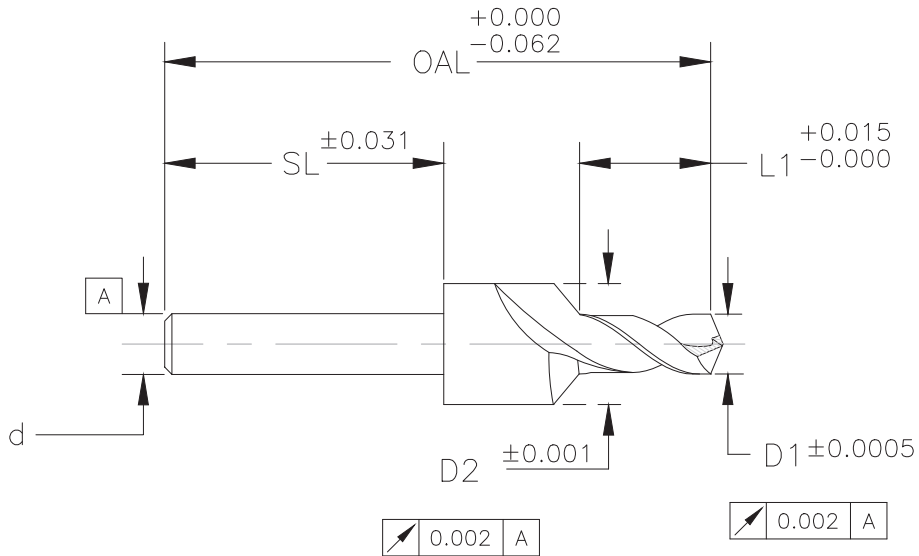

TOOL DIMENSIONS

D1 _____
 D2 _____
 L1 _____
 L2 _____
 SL _____
 OAL _____

SPECIAL TOLERANCES

Material(s) Cut _____
 Hardness _____
 Quantity Breaks _____
 (Min. 6 pieces)
 Coating _____

SOLID CARBIDE DRILL REAMER QUOTE REQUEST FORM

1081 S. Northpoint Blvd. • Waukegan, Illinois 60085 • Phone (847) 362-1560 • Fax (800) 557-6720 • www.onsrud.com

Drill Reamers are designed for single-pass drilling and reaming to achieve a final hole size with a one-step process. The tools are constructed with four reamer margins which maximize hole roundness and are capable of holding size to a tighter tolerance than drilling alone. They are designed for use in Aluminum, Composite and Titanium.

Usage: CP • Material: Composites

END USER INFORMATION

DISTRIBUTOR INFORMATION

Company _____
 Contact _____
 Address _____

 Phone _____
 Fax _____
 Email _____

Distributor _____
 Contact _____
 Phone _____
 Fax _____
 Email _____

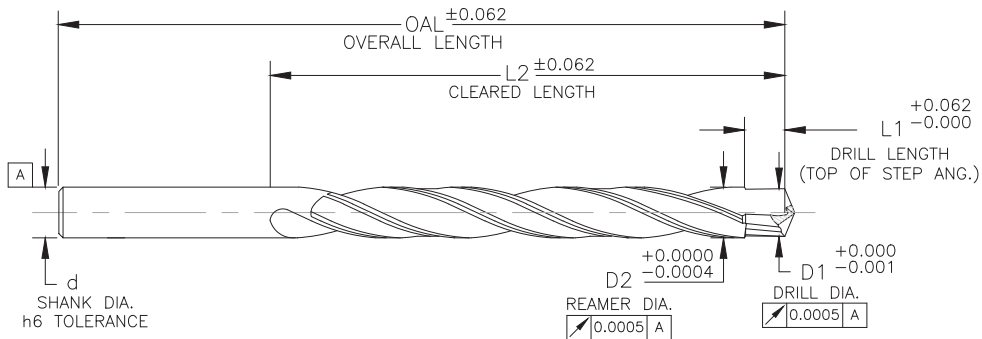

TOOL DIMENSIONS

SPECIAL TOLERANCES

D1 _____
 D2 _____
 L1 _____
 L2 _____
 d _____
 OAL _____

Material(s) Cut _____
 Hardness _____
 Quantity Breaks _____
 (Min. 6 pieces)
 Coating _____

SOLID CARBIDE CORE DRILL QUOTE REQUEST FORM

1081 S. Northpoint Blvd. • Waukegan, Illinois 60085 • Phone (847) 362-1560 • Fax (800) 557-6720 • www.onsrud.com

Core drills are used to enlarge a drilled or punched hole. These drills are often used as a second pass tool in a multi-step drilling process. This style of drill greatly increases the hole quality and accuracy compared to a 2 flute drill. With a proper set up, the core drill should produce a hole within +/- .002".

Usage: CP • Material: Composites

END USER INFORMATION

Company _____
 Contact _____
 Address _____

 Phone _____
 Fax _____
 Email _____

DISTRIBUTOR INFORMATION

Distributor _____
 Contact _____
 Phone _____
 Fax _____
 Email _____

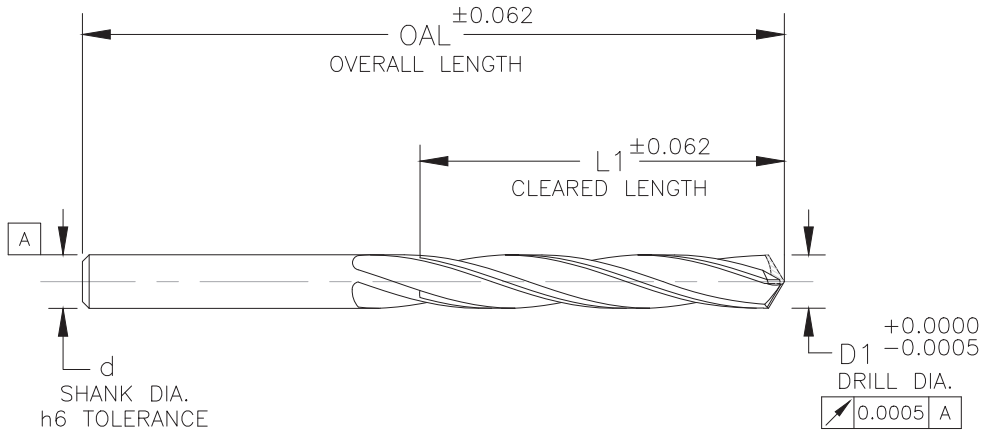

TOOL DIMENSIONS

SPECIAL TOLERANCES

D1 _____
 L1 _____
 d _____
 OAL _____

Material(s) Cut _____

Hardness _____

Quantity Breaks _____
 (Min. 6 pieces)

Coating _____

SOLID CARBIDE DAGGER DRILL QUOTE REQUEST FORM

1081 S. Northpoint Blvd. • Waukegan, Illinois 60085 • Phone (847) 362-1560 • Fax (800) 557-6720 • www.onsrud.com

Dagger drills are used to cut single sheet material which is usually carbon fiber, or woven or tape graphite epoxy. The feed rate must be controlled in order to prevent fiber breakout.

Usage: CP • Material: Composites

END USER INFORMATION

Company _____
 Contact _____
 Address _____

 Phone _____
 Fax _____
 Email _____

DISTRIBUTOR INFORMATION

Distributor _____
 Contact _____
 Phone _____
 Fax _____
 Email _____

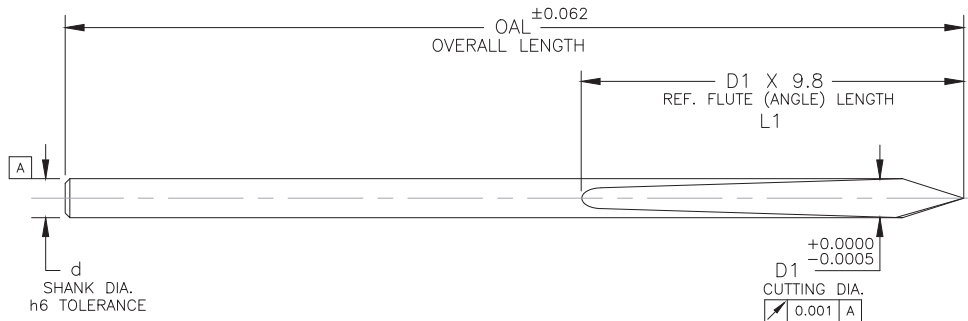

TOOL DIMENSIONS

D1 _____
 L1 _____
 d _____
 OAL _____

SPECIAL TOLERANCES

Material(s) Cut _____
 Hardness _____
 Quantity Breaks _____
 (Min. 6 pieces)
 Coating _____

SOLID CARBIDE REAMER QUOTE REQUEST FORM

1081 S. Northpoint Blvd. • Waukegan, Illinois 60085 • Phone (847) 362-1560 • Fax (800) 557-6720 • www.onsrud.com

Reamers are used to accurately size a hole. The accuracy and hole quality will be based on the condition of the roughed hole. With a proper set up, the reamer should produce a hole within +/- .001".

Usage: CP • Material: Composites

END USER INFORMATION

Company _____
 Contact _____
 Address _____

 Phone _____
 Fax _____
 Email _____

DISTRIBUTOR INFORMATION

Distributor _____
 Contact _____
 Phone _____
 Fax _____
 Email _____

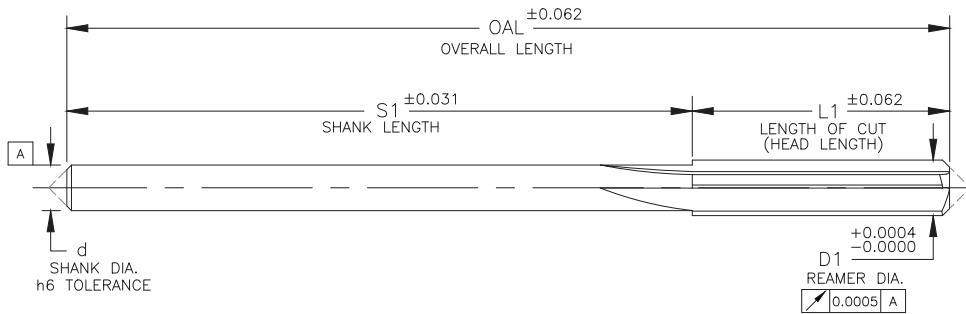

TOOL DIMENSIONS

SPECIAL TOLERANCES

D1 _____
 L1 _____
 S1 _____
 d _____
 OAL _____

Material(s) Cut _____

Hardness _____

Quantity Breaks _____
 (Min. 6 pieces)

Coating _____

CUTTING TOOL QUOTE REQUEST FORM

1081 S. Northpoint Blvd. • Waukegan, Illinois 60085 • Phone (847) 362-1560 • Fax (800) 557-6720 • www.onsrud.com

*Starred Items = Required information

*Distributor Name _____ *Distributor's Reference Number _____

*Distributor Address _____

*Contact _____ *Email Address _____

*Telephone _____ *Fax _____

End User Name _____ Customer Reference Number _____

End User Address _____

Contact _____ Email Address _____

Telephone _____ Fax _____

*Material being machined _____ Hardness _____

Machine type (Check all that apply): CNC Router CNC Mill Inverted Air Router Hand Other

If other, describe _____

H.P.= _____

Max. Spindle Speed _____ Coolant Type _____

*Tool Material: HSS Solid Carbide Carbide Tip Powder Metal PCD Full Face PCD Tip Other

If other, describe _____

*Flute Style: Spiral Up Spiral "O" Up Straight "V" Flute Compression
 Spiral Down Spiral "O" Down Straight "O" Flute Morise Compression

*Flute Form: Rougher Chipbrk/Finisher Finisher Other

*Point Geometry: Square Ball Nose Drill Point Other
 Center Cutting Non-Center Cutting

*If other, describe _____

*Tool Similar To: _____

Number of Flutes _____

Cutting Diameter (CED) _____

Cutting Length (CEL) _____

Shank Diameter (SHK) _____

Overall Length (OAL) _____

Neck Diameter (ND) _____

Neck Radius (NL) _____

Corner Radius (CR) _____

Coolant Through Yes No

Transition Grind Needed _____

Flat Y / N What Type? _____

Coating Types: TiN TiCN AlTiN Diamond Grit ZrN TiAlN DFC Diamond "Like" Other

If other, describe _____

*Quantities Needed: _____

Minimum is 6 pieces

Any Target Pricing? _____

Distributor / End User? _____

Additional Notes: _____

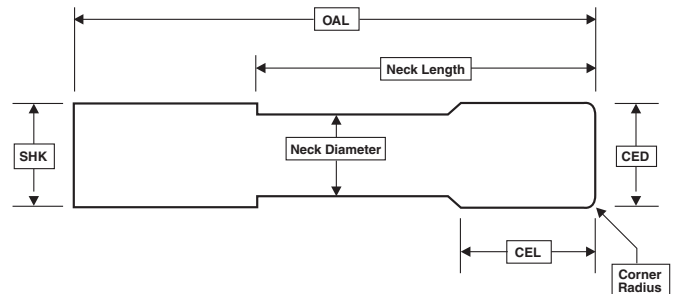

LMT Onsrud Terms & Conditions

Shipping - F.O.B. Waukegan, IL. All shipments ground unless otherwise specified.

Claims – Any claims for shortage, damage or loss must be made within 30 days of invoice date. United Parcel Service is a preferred method of shipment because of reliability and ease of tracing problem shipments.

Guarantee - Our products are guaranteed against defects in material and quality of manufacture when used in the proper manner. If tools are returned and found to be defective, we will repair or replace the tools. Continued tool breakage caused by improper tool usage without the knowledge of LMT Onsrud's technical staff is not a condition for return and replacement of such tools.

Errors - LMT Onsrud, LP cannot be held responsible for incorrect parts made with our products due to mislabeling or defect.

Return Goods Policy – No merchandise can be returned without prior authorization. Credit will not be issued for merchandise returned without a return authorization number. Product must be a current revision catalog item in new and saleable condition. All returns subject to a 15% restocking fee or offsetting order of equal value.

Specials - LMT Onsrud, LP has the right to over or under ship by 10% all specials. Special orders less than 10 pieces are subject to +/- 1 piece. Specials and modified tools are not returnable for credit. Specials cancelled will be assessed an in-process charge based on the status of the order and expenses incurred at the time of cancellation. If a special tool has been completed, the tool will be shipped and the price quoted will be billed.

Safety Precautions – Cutting tools should only be used to perform operations that are compatible with the original tool design. Safety glasses and other appropriate safety equipment should be worn by all people in the vicinity of tool use.

Prices & Terms - All prices and terms are subject to change without notice. All orders are subject to acceptance at LMT Onsrud.



Distributed by:



Toll Free: 1.800.277.7898
www.piedmontplastics.com